

Features:

- Design Capacities of 134 to 1886 GPH
- Discharge Pressures to 215 PSIG
- Metering Accuracy of $\pm 0.5\%$
- 10:1 Turndown via Stroke Length
- Internal Hydraulic Relief Valve
- Modular Design for Ease of Upgrades
- Multiple Options for Custom Solutions
- Specifically Matched Accessories
- API 675 & HI Standards Compliant

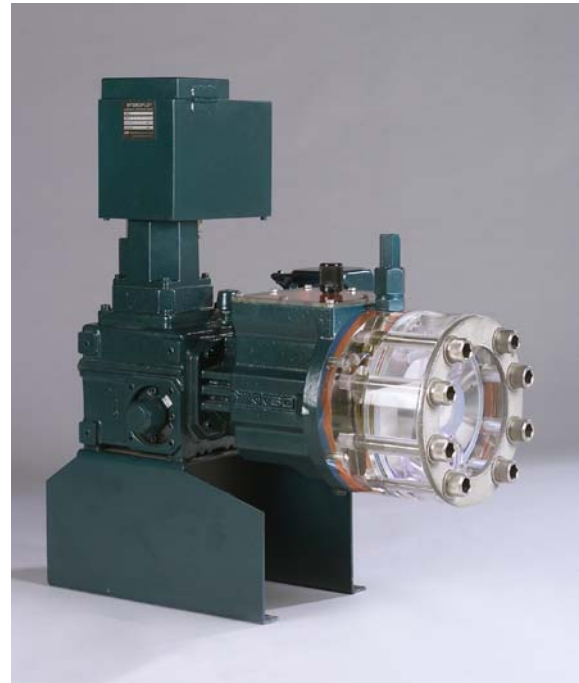

Performance Table*				
Capacity (GPH)	Pressure (PSIG)	Speed (SPM)	Plunger Diameter	Connection
134	215	32	80 mm	2 1/2" x 2 1/2"
269		65		
351		85		
439		105		
540		130		
703		170		
174	215	32	90 mm	2 1/2" x 2 1/2"
348		65		
454		85		
567		105		
698		130		
909		170		
252	145	32	110 mm	3" x 3"
505		65		
657		85		
821		105		
1011		130		
1315		170		
364	100	32	130 mm	3" x 3"
729		65		
949		85		
1185		105		
1459		130		
1886		170		

*Simplex capacities shown. Multiply for multiplex pumps.

The NIKKISO Milflo™ MX Series 5000 is a high performance, state-of-the-art, hydraulically actuated, diaphragm metering pump. The pump is available in simplex or multiplex configurations, with independent capacity adjustment for each pumphead.

All drive parts are fully enclosed and operate in an oil bath which minimizes friction and wear while providing protection from harsh environments. NIKKISO Milflo™ MX Series 5000 drives are all amplitude modulation design, eliminating lost motion and excess shock loads, while assuring longer pump life; and feature the new, patented technology of the X Crank for higher accuracy and efficiency.

A self-compensating hydraulic system assures automatic diaphragm position control and eliminates the need for troublesome vacuum breakers. Hydraulic valving removes any entrained air to maintain a tight hydraulic circuit and steady state accuracy.

The easy-to-read digital stroke length indication enables convenient capacity adjustment between 0.0 and 100.0% while the pump is operating or stopped. In addition to manual control, the pump can be supplied with optional automatic capacity control, making it possible for the pump to control the flow rate in proportion to various process signals. A simple, externally adjustable, internal hydraulic relief valve protects the pump and the process from pump induced overpressure situations.

NIKKISO MILFLO™

MX Series 5000

Model M4L - Low Pressure Liquid End

Custom Features	Accessories
Alternate Diaphragm Materials	NIKKISO HydroChek™ Calibration Columns
API 675 & HI Standards Compliant	NIKKISO HydroDamp® Pulsation Dampeners
Automatic Capacity Control	NIKKISO HydroDrive™ VSD's and Motor Controls
Sanitary Liquid End	NIKKISO HydroGarD® Back Pressure Valves
Double Diaphragm Liquid Ends	NIKKISO HydroGarD® Safety Relief Valves
Diaphragm Status Indication	NIKKISO HydroInjex™ Injection Assemblies
Liquid End Jacketing	NIKKISO HydroMix™ Agitators
Liquid Piston - Remote Liquid End	NIKKISO HydroTank® Liquid Handling Packages

Component	Materials of Construction				
Pumphead	316SS	Alloy 20	Hastelloy® C	PVC	Special
Check Valve Body	316SS	Alloy 20	Hastelloy® C	PVC	Special
Check Valve Seat	316SS	Alloy 20	Hastelloy® C	PVC	Special
Check Valve Element	316SS	Alloy 20	Hastelloy® C	Ceramic	Special
Diaphragm	PTFE	PTFE	PTFE	PTFE	Special
O-Rings	PTFE	PTFE	PTFE	FKM	Special

TYPICAL CONFIGURATION:

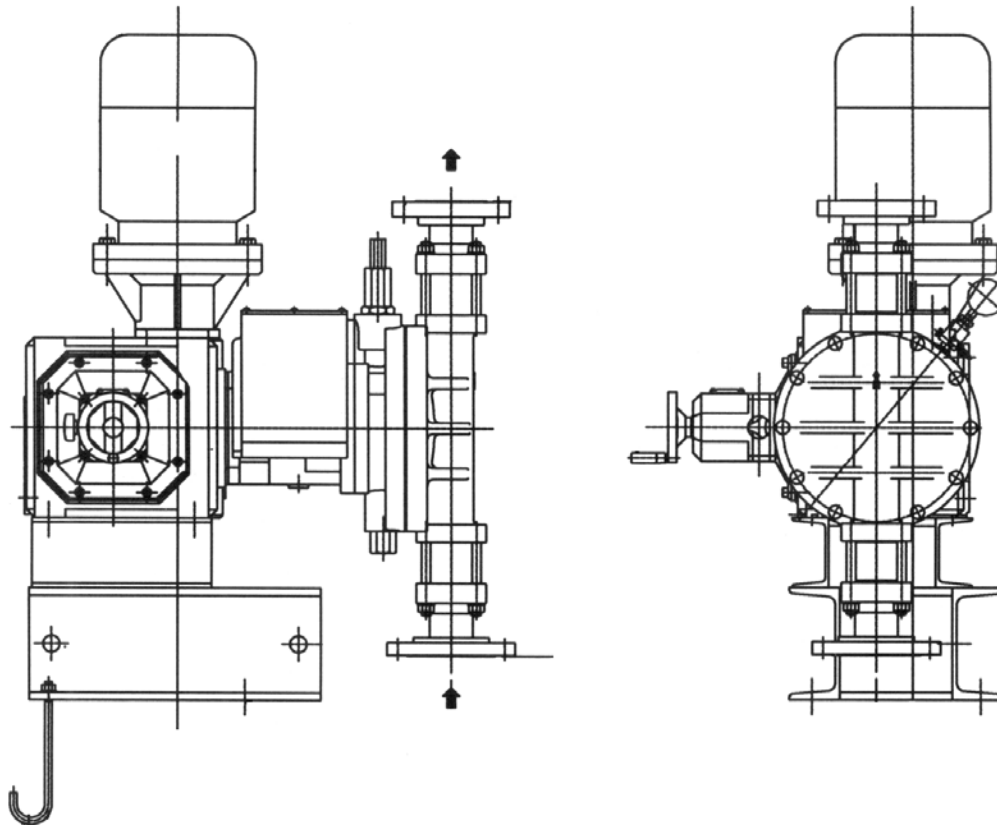

NIKKISO
Pumps America, Inc.

NIKKISO Pumps America, Inc.
6100 Easton Road • Plumsteadville, PA 18949
Phone (215) 766-7867 • Fax (215) 766-8290
email: sales@nikkisopumpsamerica.com
<http://www.nikkisopumpsamerica.com>

© 2002 NPA

Printed in U.S.A. 07/03

Bulletin 23500.24