

Features:

- Design Capacities of 7.6 to 355 GPH
- Discharge Pressures to 225 PSIG
- Metering Accuracy of $\pm 0.5\%$
- 10:1 Turndown via Stroke Length
- Internal Hydraulic Relief Valve
- Modular Design with Options
- Multiple Options for Custom Solutions
- Specifically Matched Accessories
- API 675 & HI Standards Compliant



Performance Table				
Capacity (GPH)	Pressure (PSIG)	Speed SPM	Plunger Diameter	Connection (S X D)
7.6	225	32	30 mm	1" x 3/4"
15.2		65		
19.6		85		
24.7		105		
30.4		130		
39.4		170		
12.6	225	32	40 mm	1" x 3/4"
25.2		65		
32.8		85		
41.0		105		1.5" x 1"
50.5		130		
65.7		170		
25.8	150	32	55 mm	1" x 3/4"
51.6		65		
67.2		85		
84.0		105		1.5" x 1"
103		130		
134		170		
35.6	100	32	65 mm	1.5" x 1"
71.3		65		
92.8		85		
116		105		2" x 1.5"
142		130		
185		170		
52.8	75	32	80 mm	2" x 1.5"
105		65		
137		85		
171		105		2.5" x 2"
210		130		
274		170		
68	50	32	90 mm	2" x 1.5"
136		65		
177		85		
221		105		2.5" x 2"
272		130		
355		170		

The NIKKISO Milflo™ MX Series 5000 is a high performance, state-of-the-art, hydraulically actuated, diaphragm metering pump. The pump is available in simplex or multiplex configurations, with independent capacity adjustment for each pumphead.

All drive parts are fully enclosed and operate in an oil bath which minimizes friction and wear while providing protection from harsh environments. NIKKISO Milflo™ MX Series 5000 drives are all amplitude modulation design, eliminating lost motion and excess shock loads, while assuring longer pump life; and feature the new, patented technology of the X Crank for higher accuracy and efficiency.

A self-compensating hydraulic system assures automatic diaphragm position control and eliminates the need for troublesome vacuum breakers. Hydraulic valving removes any entrained air to maintain a tight hydraulic circuit and steady state accuracy.

The easy-to-read digital stroke length indication enables convenient capacity adjustment between 0.0 and 100.0% while the pump is operating or stopped. In addition to manual control, the pump can be supplied with optional automatic capacity control, making it possible for the pump to control the flow rate in proportion to various process signals. A simple, externally adjustable, internal hydraulic relief valve protects the pump and the process from pump induced overpressure situations.

Simplex capacities shown. Multiply for multiplex pumps.

NIKKISO MILFLO™

MX Series 5000

Model M2L - Low Pressure Liquid End

Custom Features	Accessories
Alternate Diaphragm Materials	NIKKISO HydroChek™ Calibration Columns
API 675 & HI Standards Compliant	NIKKISO HydroDamp® Pulsation Dampeners
Automatic Capacity Control	NIKKISO HydroDrive™ VSD's & Motor Controls
Degassing Liquid End	NIKKISO HydroGarD™ Back Pressure Valves
Double Diaphragm Liquid Ends	NIKKISO HydroGarD™ Safety Relief Valves
Diaphragm Status Indication	NIKKISO HydroInjex™ Injection Assemblies
Liquid End Jacketing	NIKKISO HydroMix™ Agitators
Liquid Piston - Remote Liquid End	NIKKISO HydroTank® Liquid Handling Packages

Component	Materials of Construction				
Pumphead	316SS	Alloy 20	Hastelloy® C	PVC	Special
Check Valve Body	316SS	Alloy 20	Hastelloy® C	PVC	Special
Check Valve Seat	316SS	Alloy 20	Hastelloy® C	PVC	Special
Check Valve Element	316SS	Alloy 20	Hastelloy® C	Ceramic	Special
Diaphragm	PTFE	PTFE	PTFE	PTFE	Special
O-Rings	PTFE	PTFE	PTFE	FKM	Special

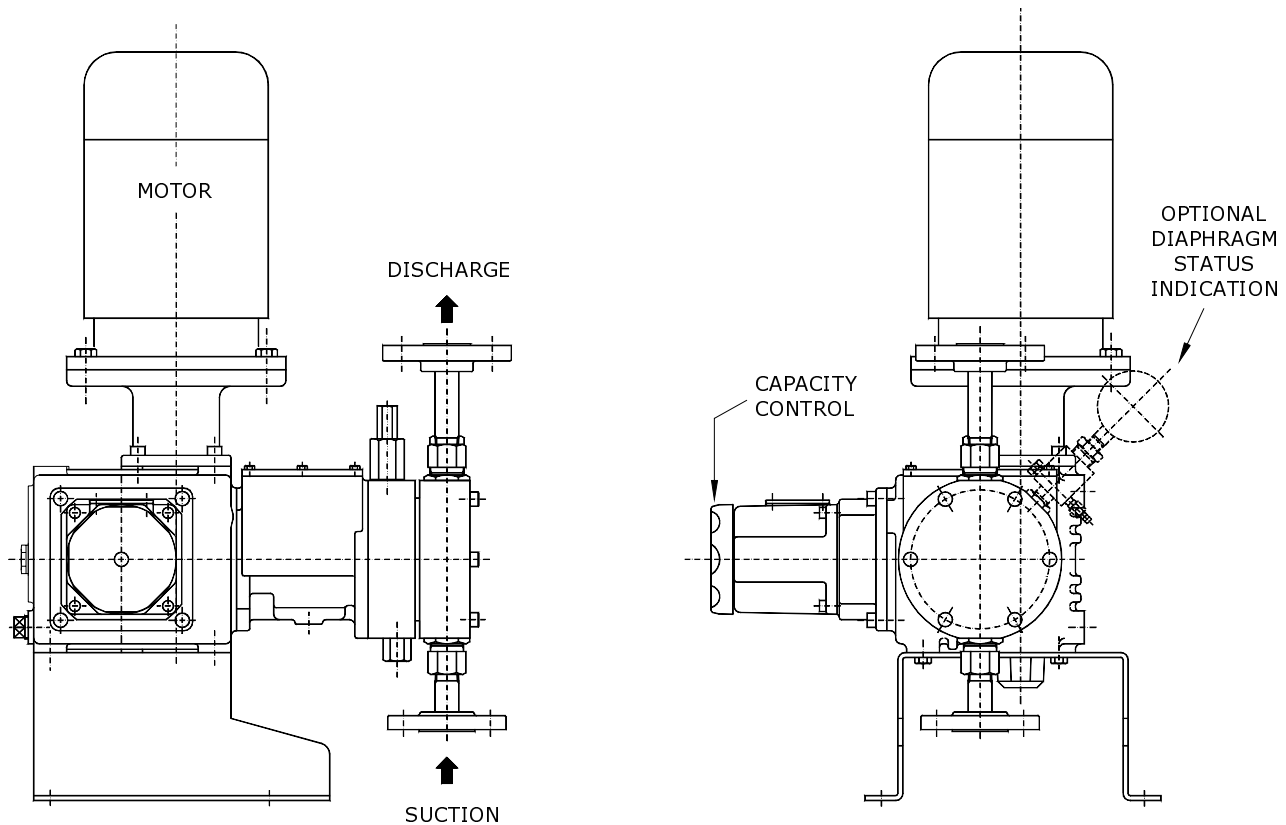

NIKKISO
Pumps America, Inc.

NIKKISO Pumps America, Inc.
6100 Easton Road • Plumsteadville, PA 18949
Phone (215) 766-7867 • Fax (215) 766-8290
email: sales@nikkisopumpsamerica.com
http://www.nikkisopumpsamerica.com

© 2002 NPA

Printed in U.S.A. 05/02

Bulletin 23500.22