

Features:

- Engineered for Low-Flow Applications
- Design Capacity of 0.005 to 3.25 GPH
- Discharge Pressures to 3,000 PSIG
- Metering Accuracy $\pm 1\%$
- 10:1 Turndown via Stroke Length
- Internal Hydraulic Relief Valve
- Modular Design with Multiple Options
- Specifically Matched Accessories



The NIKKISO Hydroflo® Series 997 is a hydraulically actuated diaphragm metering pump, specifically designed for low-flow, high-pressure chemical feed applications. Unlike other pumps, which are scaled down versions of existing high capacity designs, the Series 997 was designed from the ground up to meet market demands for a sealless, leakproof metering pump, capable of low flow rates.

The unique characteristics of the Series 997 make it particularly well suited to pumping concentrated or neat chemicals in applications such as laboratories, pilot plants, oil and gas production, pulp and paper, chemical and petrochemical services.

Performance Table								
Capacity (GPH)	Pressure (PSIG)	Speed (SPM)	Plunger Diameter	Connection (MNPT)				
0.14 0.28 0.47 0.56 0.67 0.82	3,000	29 58 97 117 140 170	3/16"	1/4"				
0.24 0.49 0.82 1.00 1.19 1.44		29 58 97 117 140 170			1/4"	1/4"		
0.55 1.11 1.86 2.24 2.69 3.25		29 58 97 117 140 170					3/8"	1/4"

The Series 997 pump utilizes separate drive housing and hydraulic chambers. The hydraulic oil is contained in environmentally sealed chamber, eliminating the need for routine hydraulic system maintenance. All drive parts are fully enclosed and operate in an oil bath, minimizing friction and wear while providing extra protection from harsh environments.

A large, easy to read micrometer knob permits convenient capacity adjustment between 0 and 100%, while the pump is stopped or in operation. Combining stroke and speed turndown, the pump is capable of flow rates as low as 0.005 GPH (0-12 GPD) at pressures to 3,000 PSIG, with metering accuracy of better than $\pm 1\%$. An adjustable hydraulic relief valve protects the pump and drive from potential overpressure damage.

Simplex capacities shown.
Double capacity for duplex pumps.

Custom Features	Accessories
Alternate Diaphragm Materials	NIKKISO HydroChek™ Calibration Columns
Automatic Capacity Control via Speed	NIKKISO HydroDamp® Pulsation Dampeners
Automatic Capacity Control via Stroke	NIKKISO HydroDrive™ VSD's & Motor Controls
Double Diaphragm Liquid Ends	NIKKISO Hydrogard™ Back Pressure Valves
Diaphragm Status Indication - Electronic	NIKKISO Hydrogard™ Safety Relief Valves
Diaphragm Status Indication - Visual	NIKKISO HydroInjex™ Injection Assemblies
Liquid End Jacketing	NIKKISO HydroMix™ Agitators
Low NPSHa Liquid Ends	NIKKISO HydroTank® Liquid Handling Package

Component	Materials of Construction		
Pumphead	316 SS	Alloy 20	Hastelloy® C
Check Valve Body	316 SS	Alloy 20	Hastelloy® C
Check Valve Seat	316 SS	Alloy 20	Hastelloy® C
Check Valve Element	316 SS	Alloy 20	Hastelloy® C
Diaphragm	PTFE	PTFE	PTFE
Contour Plate	316 SS	Alloy 20	Hastelloy® C
O-Rings	FKM	FKM	FKM
Oil Reservoir Cover	Aluminum	Aluminum	Aluminum
Stroke Control Knob	Aluminum	Aluminum	Aluminum

Dimensions: (inches – reference only)

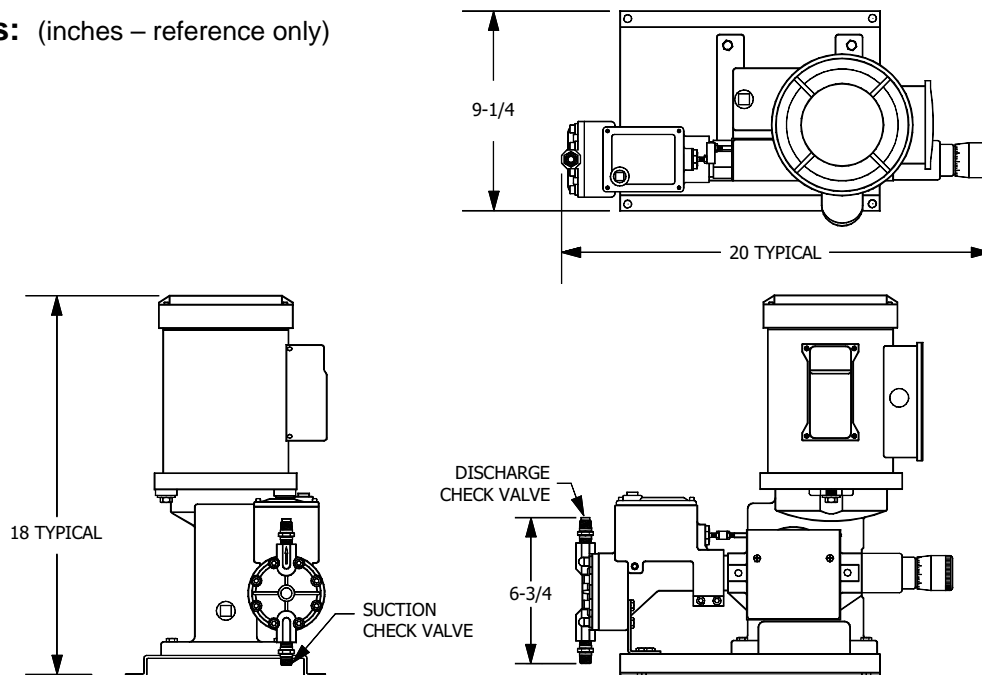

NIKKISO
Pumps America, Inc.

NIKKISO Pumps America, Inc.
6100 Easton Road • Plumsteadville, PA 18949
Phone (215) 766-7867 • Fax (215) 766-8290
email: sales@nikkisopumpsamerica.com
http://www.nikkisopumpsamerica.com

© 2002 NPA

Printed in U.S.A. 12/02

Bulletin 23090.21