



NIKKISO NON-SEAL Pump

SGM Large Capacity Series

Basic Type (4P Motor)

■ Instruction Manual ■

Manual No. 2200 R1

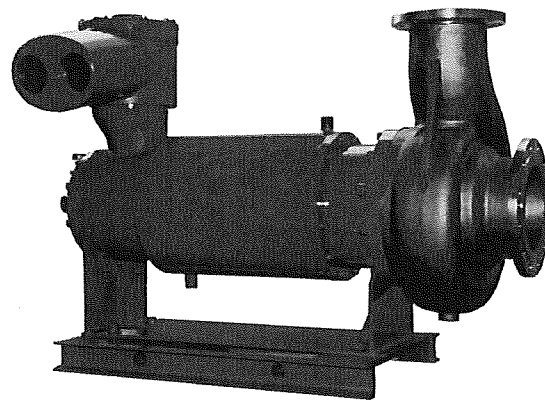

PRECAUTIONS

1. Read this instruction manual prior to installation, piping and operation.
2. This manual must be kept where anyone who uses this equipment actually can read it easily.
3. If this equipment is used at any specifications other than the contract specifications, the manufacturer can bear no responsibility for the result.

Introduction

- (1) This instruction manual relates to operation and maintenance for safe use of NIKKISO NON-SEAL Pump SGM Large Capacity Series (4P Motor) Basic Type.

To secure the safety, do not allow persons who are not knowledgeable on the pump to carry out operation or maintenance. Persons in charge of operation or maintenance should read this manual carefully before starting installation, wiring or operation.

Keep this manual in a place easily accessible to persons who operate the pump whenever required.

- (2) Items requiring attention for safety reasons are headed with .

These meanings are described in "Safety Precautions" on the next page.

Please have a thorough understanding of these items before starting operation.

- (3) Note that the following items are outside the range of our responsibility.

- ① Accident caused by mode of use not conforming to contracted specification
- ② Accident caused by mode of use not described in instruction manual or not conforming to instructions described
- ③ Accident caused by using parts other than NIKKISO genuine parts or parts specified by NIKKISO
- ④ Corrosion of pump caused by liquid handled

- (4) If the pump needs to be modified, be sure to contact NIKKISO beforehand.

- (5) Be sure to carry out periodic inspections according to the description in this instruction manual.

- (6) If the instruction manual is damaged or lost, or if you want to check the specification of the product, contact your nearest NIKKISO office described on the back cover of this manual. In that case, inform us of the manufacturing number and model number described in the delivery specification or name plate of the corresponding product.

- (7) Product(s) (including parts, technical data or information thereto) described in this manual shall be subject to export control laws and regulations of Japan or the US. You need to obtain the approval from appropriate government(s) when you export if such laws and regulations require.

SAFETY PRECAUTIONS

Before starting installation, operation, maintenance or inspection, be sure to read this instruction manual and other attached documents carefully for correct use. Make sure you understand all about the equipment, safety information and cautions before using the product.

<Definition of symbols indicating cautions>

The  mark used in this instruction manual has the following meaning.

 mark: This mark is posted on places requiring attention before starting operation or maintenance, etc.

This mark is followed by DANGER, WARNING or CAUTION with reasons for requiring attention.

These are important items for safety reasons and should be observed absolutely.

◎ The following shows categories and descriptions of danger or degree of damage caused by improper handling of the product.

 **DANGER** : indicates an imminently hazardous situation which, if not avoided, will result in death or serious injury.

 **WARNING** : Indicates a potentially hazardous situation that may result in death or serious injury in the event of improper handling.

 **CAUTION** : Indicates a potentially hazardous situation that may result in light to moderate injuries or only in property damage in the event of improper handling.

NOTE : Indicates reference information.

⚠ WARNING

1. During installation

- (1) Be sure to ground (connect a grounding conductor) the motor. Electric shock may result otherwise.

2. During disassembly

- (1) Always turn off the power supply to the motor, otherwise there is a possibility of receiving an electric shock.
- (2) When the handled liquid is hazardous, remove or replace the hazardous liquid before attempting disassembly by flushing with safe liquid or other similar procedure. When disassembling a pump, wear appropriate personal protective equipment.

3. During repair by manufacturer

- (1) When returning the product to the NIKKISO factory for periodic inspection, etc., completely drain the liquid handled and clean the inside.

⚠ CAUTION

1. During installation or piping

- (1) When carrying out a pressure-proof test of the piping, prevent the test pressure from applying to the pump. This may cause damage to the pump.

2. During operation

- (1) Avoid no-load running or no-discharge running. This may cause damage to the pump.
- (2) Do not operate the pump with cavitation or surging. This may cause damage to the pump and piping.
- (3) When the safety device or alarm device is activated, immediately stop the pump, investigate the cause and remove the anomalies before restarting operation.

SAFETY ALERT LABELS

The following are caution or warning labels to secure the safety during operation or maintenance. When these labels are illegible or lost, put them again or replace them with new ones.

When the labels are replaced, contact NIKKISO at the address described on the back cover of this manual.

[Warning label location]

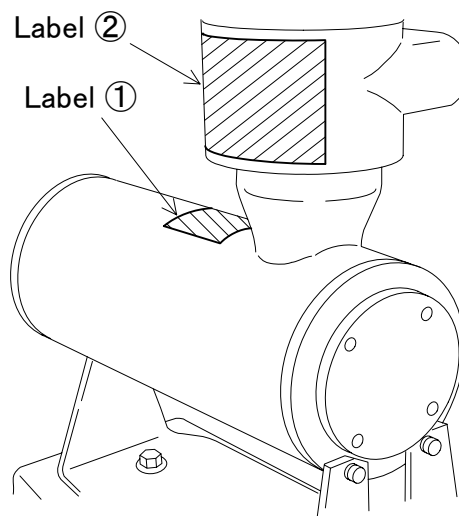

Fig. 1 Caution and Warning Label Locations

[Description of label]

Label ①



Label ② Main name plate

FLAMEPROOF CONSTRUCTION [14] APPROVED IN RIGHT No. OF [16]		NIKKISO NIKKISO NON-SEAL® PUMP		CAUTION READ INSTRUCTION MANUAL(S) CAREFULLY TO USING THE PUMP 1. Don't run dry 2. Before start up, be sure to vent entire pump and motor unit properly 3. Never restart without solving the cause when the protective device works and pump is stopped 4. Don't operate under any of the following conditions which result in serious hazards Fluid leakage from any joints Blocked discharge and suction lines Bearing Monitor in red zone 5. Don't disassemble terminal plate in the terminal box.
BY MINISTRY OF LABOUR, THE RESEARCH INSTITUTE OF INDUSTRIAL SAFETY, JAPAN		ITEM NO. [1]	MODEL [2]	
MAX TEMP. AT MOTOR INLET [15] °C COOLING WATER MAX. TEMP. [17] °C COOLING WATER MIN. CAP. [18] ℓ/min HOT WATER MAX. TEMP. [19] °C HOT WATER MIN. CAP. [20] ℓ/min STEAM MAX. TEMP. [21] °C		HEAD [3] m CAP [4] ℓ/min	OUTPUT [5] kW	
		[6] V 3 φ [7] Hz	SYN. [8] rpm INS. CL. [9]	
		F. L. A [10] A START. A [11] A	MAX. LIQ. TEMP [12] °C	
		DATE	SER. NO. [13]	
		NIKKISO CO., LTD. TOKYO JAPAN		

- [1] ITEM NO : Indicates specified item number.
- [2] MODEL : Indicates model number.
- [3] HEAD : Indicates complete head of pump.
- [4] CAP. : Indicates discharge flow rate of pump.
- [5] OUTPUT : Indicates rated output of pump.
- [6] V : Indicates motor voltage.
- [7] Hz : Indicates motor frequency.
- [8] SYN. : Indicates synchronous rpm of motor.
- [9] INS. CLASS : Indicates insulation class of motor.
- [10] F.L.A. : Indicates full load current of motor.
- [11] START.A : Indicates start current of motor.
- [12] MAX. LIQUID TEMP. : Indicates maximum liquid temperature of motor.
- [13] SER. NO. : Indicates serial number of pump.
- [14] FLAMEPROOF CONSTRUCTION : Indicates explosion-proof structure.
- [15] MAX. LIQ. TEMPERATURE : Indicates maximum liquid temperature at the motor inlet.
- [16] APPROVED IN RIGHT No. OF: Indicates APPROVED IN RIGHT No.
- [17] COOLING WATER MAX. TEMP.
- [18] COOLING WATER MIN. CAP.
- [19] HOT WATER MAX. TEMP.
- [20] HOT WATER MIN. CAP.
- [21] STEAM MAX. TEMP.

CONTENTS

Introduction	i
SAFETY PRECAUTIONS	ii
SAFETY ALERT LABELS	iv
Section 1 Construction	§ 1-2
1.1 Names of Various Parts	§ 1-2
Section 2 Installation and Piping	§ 2-1
2.1 Unpacking	§ 2-1
2.2 Installation	§ 2-2
2.3 Main Piping	§ 2-3
2.3.1 Precautions	§ 2-3
2.4 Ancillary Apparatus	§ 2-4
2.4.1 Pressure Gauge	§ 2-4
2.4.2 Strainer	§ 2-4
2.4.3 Valve	§ 2-4
2.5 Auxiliary Piping	§ 2-5
2.5.1 Cooling Water Piping for Motor Peripheral Jacket	§ 2-5
2.5.2 Drain/Vent Piping	§ 2-6
2.6 Starter	§ 2-7
2.7 Overheat Protection Circuit	§ 2-8
2.8 Terminal Box and Resistance Measurement	§ 2-10
2.8.1 Terminal Box	§ 2-10
2.8.2 E Monitor Terminal Box	§ 2-11
2.8.3 Check of Insulation Resistance	§ 2-16
2.8.4 Measurement of Winding Resistance	§ 2-16
2.9 Connections	§ 2-18
Section 3 Operation	§ 3-1
3.1 Items to be Confirmed Before Operation	§ 3-1
3.1.1 Direction of Motor Rotation	§ 3-1
3.1.2 Confirmation of Direction of Rotation (1)	§ 3-2

3.1.3	Confirmation of Direction of Rotation (2)	§ 3-2
3.1.4	Check of Bearing Monitor (In the Case of Mechanical Type)	§ 3-2
3.2	Starting	§ 3-3
3.2.1	Preparations for Starting	§ 3-3
3.2.2	Startup Procedure	§ 3-4
3.3	Stopping	§ 3-6
3.3.1	Normal Stopping	§ 3-6
3.3.2	Long-Term Shutdown	§ 3-6
3.3.3	Starting after a Long-term Shutdown	§ 3-7
3.4	Care during Steady-State Operation	§ 3-8
3.4.1	Items to be Checked during Steady-State Operation	§ 3-8
3.4.2	Emergency Stopping	§ 3-9

Section 4 Check and Maintenance..... § 4-1

4.1	Daily Check	§ 4-1
4.2	Method of Disassembly	§ 4-2
4.3	Check of Bearing	§ 4-10
4.3.1	Life of Bearing	§ 4-10
4.4	Bearing Monitor	§ 4-11
4.4.1	Mechanical Type Bearing Monitor	§ 4-11
4.4.2	E Monitor	§ 4-13
4.5	Method of Reassembly	§ 4-16

Section 5 Troubleshooting..... § 5-1

5.1	Troubleshooting	§ 5-1
-----	-----------------------	-------

Section 6 Periodical Check..... § 6-1

6.1	Implement of Periodical Check	§ 6-1
6.2	Items to be checked in Periodical Check	§ 6-1

Section 7 Spare Parts..... § 7-1

7.1	Spare Parts	§ 7-1
-----	-------------------	-------

Section 8 Services..... § 8-1

8.1	Check	§ 8-1
8.2	In the Event of Damage	§ 8-1
8.3	When Returning	§ 8-2

NIKKISO NON-SEAL Pump

SGM Large Capacity Series Basic Type

Section 1 Construction

Section 2 Installation and Piping

Section 3 Operation

Section 4 Check and Maintenance

Section 5 Troubleshooting

Section 6 Periodical Check

Section 7 Spare Parts

Section 8 Services

NO.	PART NAME	Q'TY
S36	Stator ass'y	1
V01	Air vent valve	1
W01A	Washer ass'y	1
W05	Thrust washer	2
W072	Tongued washer	1
111	Bolt	12
113	Bolt	8
131	Bolt	16
141	Bolt	2
142	Bolt	4
153	Grounding terminal bolt	1
212	Bolt	8
221	Bolt	4
222	Bolt	4
224	Bolt	4
231	Bolt	2
311	Gasket	1
312	Gasket	1
313	Gasket	1
314	Gasket	1
331	Gasket	2
611	Plug	1
613	Plug	1

NO.	PART NAME	Q'TY
B012	Bearing	2
B05	Base	1
B20	Impeller bolt	1
B28	Terminal box ass'y	1
C20	Casing	1
C30	Rear cover	1
D05	Liner disk	1
H13	FB housing	1
H14	RB Housing	1
J01	Jacket	1
J12	Impeller	1
K011	Key	1
K012	Key	2
L05	Stator liner	1
M07	Bearing monitor	1
N02	Nut	1
N07	End nut	1
P11	Cover plate	2
P22	Adaptor plate	1
R16	Rotor ass'y	1
S03	Shaft	1
S17	Stand	1
S22	Spacer	1
S26	Sheet	2
S29	Rotor sleeve	1
S30	Shaft sleeve	2

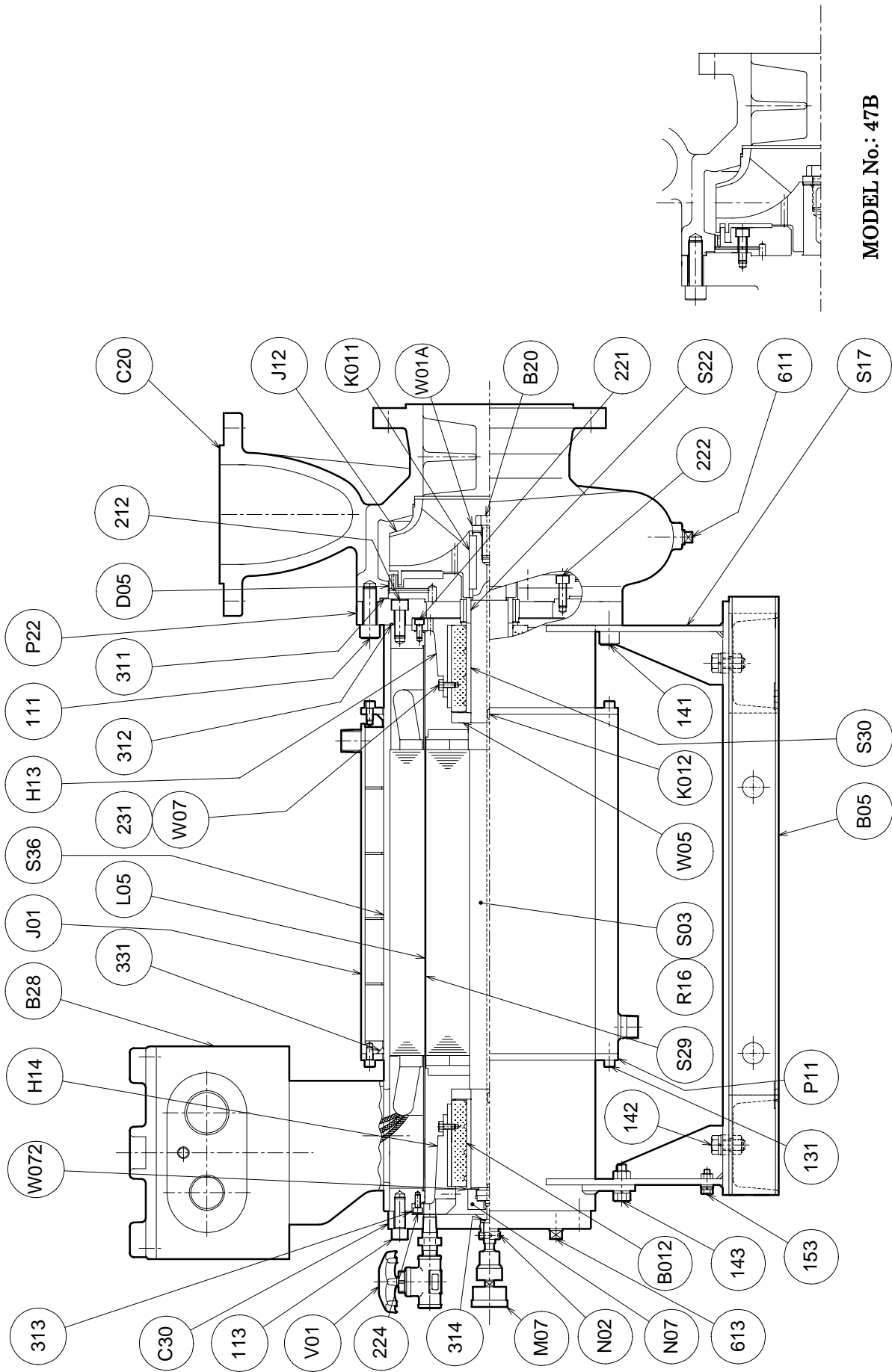

MODEL No.: 47B

Fig. 1-2 HN Type (Basic, Horizontal), NIKKISO NON-SEAL™ PUMP (Motor Frame No. J and K)

No.	名称	個数
V01	Air vent valve	1
W01A	Washer ass'y	1
W05	Thrust washer	2
W07	Washer	2
W072	Tongued washer	1
111	Bolt	12(16)
113	Bolt	8
131	Bolt	24
141	Bolt	2
142	Bolt	4
143	Bolt	2
153	Grounding terminal bolt	1
212	Bolt	16
221	Bolt	8
222	Bolt	2
224	Bolt	1
231	Bolt	1
311	Gasket	1
312	Gasket	1
313	Gasket	1
314	Gasket	1
331	Gasket	2
611	Plug	1
613	Plug	1

No.	名称	個数
B012	Bearing	2
B05	Base	1
B20	Impeller bolt	1
B28	Terminal box ass'y	1
C20	Casing	1
C30	Rear cover	1
D05	Liner disk	1
H13	FB housing	1
H14	RB housing	1
J01	Jacket	1
J12	Impeller	1
K011	Key	1(2)
K012	Key	2
L05	Stator liner	1
M07	Bearing monitor	1
N02	Nut	1
N07	End nut	1
P11	Cover plate	2
P22	Adaptor plate	1
R16	Rotor ass'y	1
S03	Shaft	1
S17	Stand	1
S22	Spacer	1
S29	Rotor sleeve	1
S30	Shaft sleeve	2
S36	Stator ass'y	1

2 Installation and Piping

2.1 Unpacking

⚠ CAUTION

Do not remove covers from pump suction/discharge ports and other openings before pump installation. If foreign substances get into the pump, they may cause trouble.

Upon unpacking, check the contents for any damage or missing part in transit. Normally, the pump is packed with instruction manuals, spare parts and accessories. When unpacking, take care as follows.

- (1) When unpacking a large number of pumps at the site of construction, confirm Serial No. of each pump to prevent confusion of the pumps. (Refer to Fig.2-1.)
- (2) Mark spare parts and accessories with the pump Serial No. clearly.
- (3) Pump test reports will be furnished later. Confirm the pump Serial No. marked on the reports and keep them in separate custody.
- (4) Do not remove seals from pump inlet and outlet before pump installation. If foreign substances get into the pump, they may cause trouble.
- (5) Even if the pump is to be stored for a long time in a warehouse, check the pump for the above items upon receipt and give antirusting treatment before storage.
- (6) In case any damage is found with the pump, immediately contact the transportation company or NIKKISO.

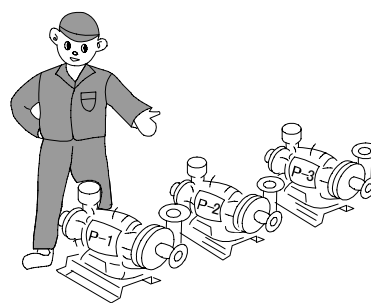

Fig.2-1 Confirmation Upon Unpacking

2.2 Installation

⚠ CAUTION

Install the pump as near as possible to the suction vessel to be suctioned. Make sure NPSH conditions are met.

⚠ CAUTION

Configure the piping so that the pump is not subjected to the weight and thermal stress thereof. (Refer to Fig. 2-2.)

Note the following points during installation:

- (1) Check the pump item number and make sure the information on the nameplate is consistent with specifications.
- (2) Provide sufficient working space around the pump and above the pump to perform maintenance.

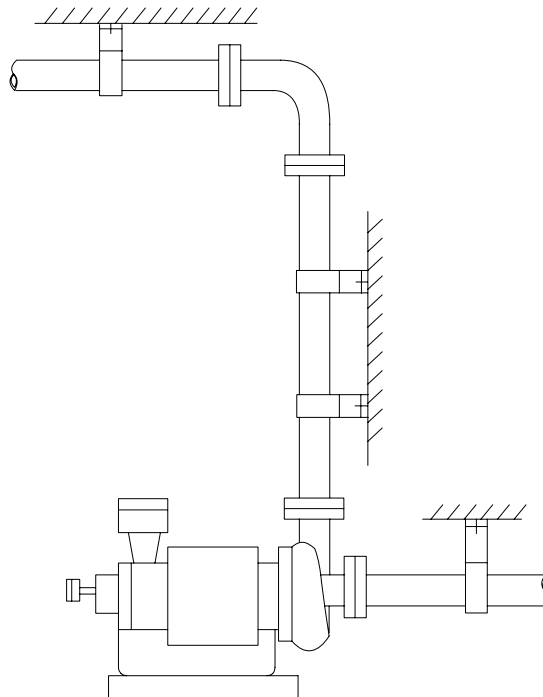

Fig.2-2 An Example of How to Support Piping

2.3 Main Piping

2.3.1 Precautions

For pump inlet and outlet piping systems, calculate the respective pipeline resistances and use the optimum pipelines.

CAUTION

Especially, for the suction side piping, select the pipe diameter so that the NPSH condition may be satisfied sufficiently.

Moreover, before starting the operation, conduct air-tightness test, etc. of piping systems (especially, the suction pipe) to confirm that there is no air ingress.

When making the piping, confirm the following items.

- (1) Remove burrs, etc. at pipe ends and flanges.
- (2) In the case of flanges, make sure that the pipe inside diameter and gasket, etc. coincide in strict concentricity and there are no air pockets or foreign substance accumulations in that portion.
- (3) Prevent air pockets from being formed in the piping and use as less elbows and bends as possible.
- (4) When connecting pipelines of dissimilar diameters, use eccentric reducers and avoid formation of air pockets.

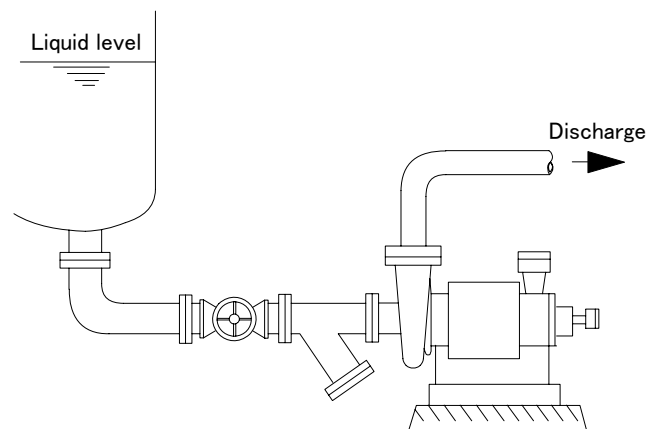

Fig.2-3 An Example of Suction Side Piping

2 Installation and Piping

2.4 Ancillary Apparatus

For the main piping, use the following apparatus. (Refer to Fig.2-4.)

2.4.1 Pressure Gauge

Mount the pressure gauge B on the pump outlet side without fail, to aid in monitoring the operation.

Especially, in the case of the Non-Seal pump, the condition of operation is not visible from outside and this gauge is the more necessary. The pressure gauge should be installed between the pump and the discharge valve. On the suction side, mount the pressure gauge A between the strainer and the pump, to aid in monitoring the suction pressure whether it is decreased so as to prevent cavitation.

2.4.2 Strainer

At the beginning of operation, it is necessary to use a temporary strainer installed on the suction side even if it is expected that, after the operation has become steady, there will be no possibility of foreign substances making ingress into the liquid handled. Remove this strainer only after it has been fully confirmed that the liquid handled no longer contains foreign substances. If, after the operation has become steady, there is still a possibility of foreign substances making ingress into the liquid handled, it is necessary to use a permanent strainer.

In any case, the strainer should have 60 to 80 meshes. The strainer has a large resistance, and if it is liable to be clogged with foreign substances, the resistance is increased thereby greatly. Therefore, the strainer to be used should have sufficiently large ones. If the strainer is clogged seriously, cavitation will occur. To prevent such a trouble, monitor the suction pressure and clean the strainer periodically. The intervals of this cleaning should be determined according to the respective conditions.

When the liquid handled is a slurry, this basic type pump is not suited.

2.4.3 Valve

For the purpose of maintenance of the pump, be sure to provide a valve at the inlet and outlet of the pump. To reduce the resistance at the inlet in particular, use a cutoff valve. It is recommended to place the handle of the cutoff valve in a horizontal position to prevent air pockets.

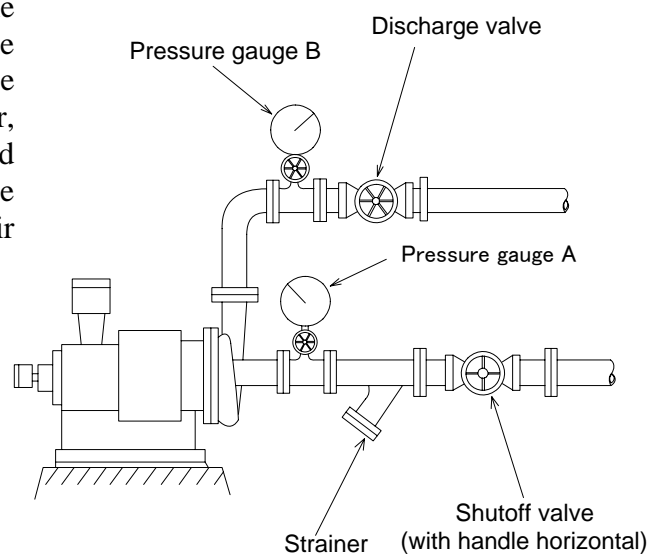

Fig.2-4 Apparatus Around the Pump

2.5 Auxiliary Piping

Normally, the Non-Seal pump of basic type requires the following kinds of auxiliary piping.

- (1) Coolant piping for motor peripheral jacket
- (2) Drain/vent piping

2.5.1 Cooling Water Piping for Motor Peripheral Jacket

For the pump provided with the motor peripheral jacket (J01), make cooling water piping. (The cooling water flow rate and the connection bore are shown in Table 2-1.)

The port located in the lowest portion of the jacket is used as the inlet for the jacket piping in either the vertical type or the horizontal type of pump. Be sure to use this port.

If the port in the upper portion is used as the inlet, air may remain in the jacket.

(Refer to Fig.2-5.)

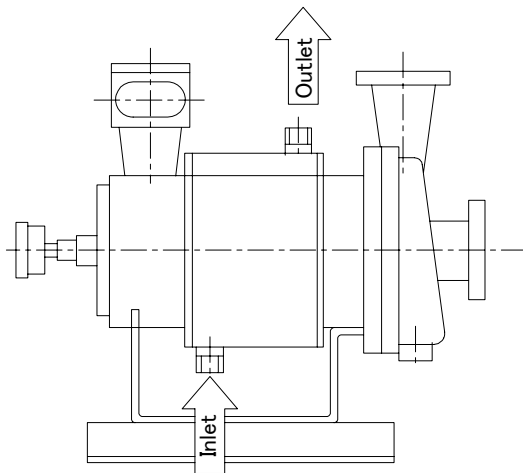

Fig.2-5 (a) Cooling Water Piping
(Horizontal type)

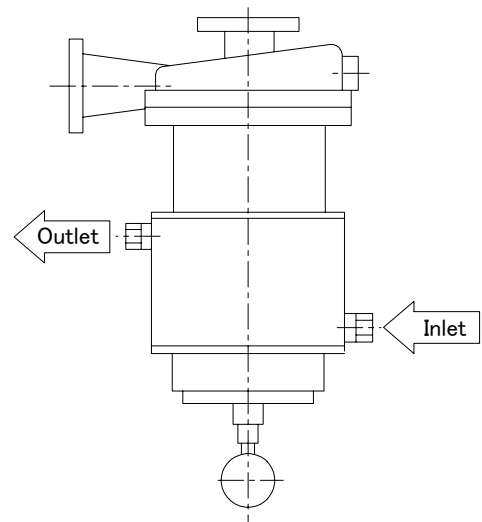

Fig.2-5 (b) Cooling Water Piping
(Vertical type)

Table 2-1 Jacket Cooling Water Flow Rate and Connection Bore Unit: m³/h

MOTOR FRAME NO.	COOLING WATER FLOW RATE		CONNECTION BORE
	LOWER LIMIT	SPECIFIED	
H1, H2	2.0	3.0	R1
J1, J2, J3, J4	3.0	4.0	(PT1)
K1, K2, K3, K4	4.0	6.0	R1 1/2 (PT1 1/2)

Values shown for the cooling water flow rate are approximate and refer to the case where the industrial water below 35°C is used.

2 Installation and Piping

2.5.2 Drain/Vent Piping

⚠ WARNING

When the pump handles a detrimental liquid, etc., or the line pressure is high, or the pump is used in a vacuum system, etc., be sure to install necessary valves and pipes to the piping.

The pump drain and the motor drain are provided usually with R1/2 (PT1/2) plug.

The vent is provided with an air vent valve.

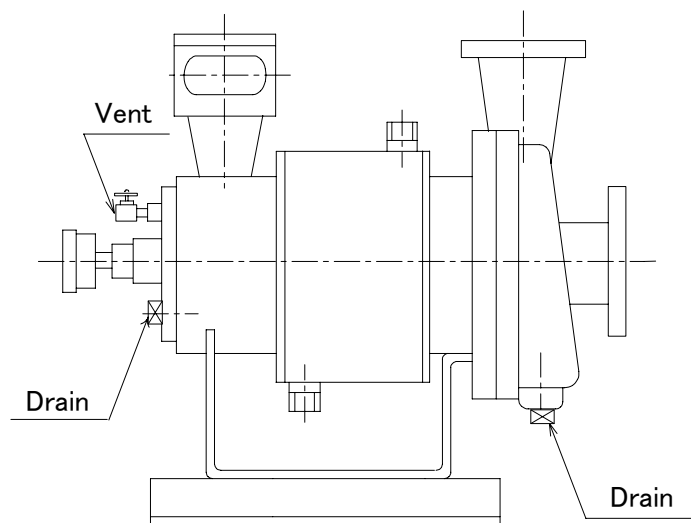

Fig.2-6 Vent/Drain

2.6 Starter

CAUTION

As the operation switch, be sure to use an electromagnetic switch. This is necessary not only for the overload protection which the electromagnetic switch gives, but also for the protection of the motor by a thermostat circuit of Fig.2-9 which is connected in series with the exciting coil of the electromagnetic switch. Moreover, install a safety circuit for the protection in the event of line-to-ground fault.

The Non-Seal pump requires relatively small starting current and short starting time, and therefore, it is applied, as a rule, with full voltage starting. However, if it is necessary to reduce the starting current for any reason of electrical equipment, etc., apply (a) transformer starting or (b) reactor starting.

Fig.2-7 shows a recommended circuit diagram for the Non-Seal pump.

The capacity of the electromagnetic switch should be selected based on the rated current value shown on the pump name plate or in the specification.

Moreover, mount an ammeter for operation monitoring. The capacity of the ammeter should be determined by reference to the starting current shown on the pump name plate or the specification. Install another ammeter in the field by the side of the pump.

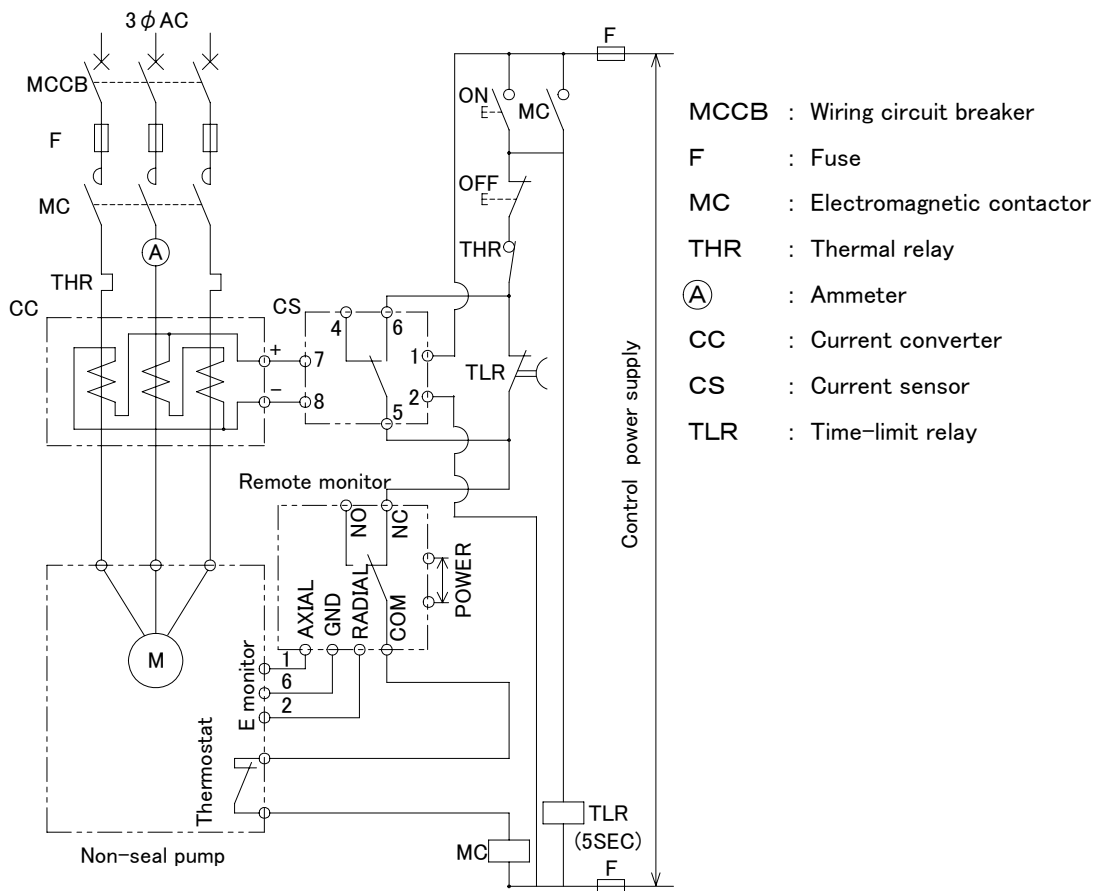

Fig.2-7 Recommended Electrical Circuit for Non-Seal Pump

2.7 Overheat Protection Circuit

For the protection of motor windings of the Non-Seal pump, a thermostat is buried at a position where the temperature becomes highest.

The thermostat is of totally enclosed type and is connected inside the motor as shown in Fig.2-7. When installing the thermostat circuit for the prevention of motor overheating, pay attention to the following points.

- (1) The thermostat has B-contacts. (Refer to Fig.2-8.)
These contacts are normally closed, and when the temperature reaches the operating temperature, then open. For the operating temperature of the thermostat, refer to Table 2-2.
 - (2) The maximum rated voltage and current of the thermostat are AC 220V and 1.5A. Under some service conditions, the thermostat operates frequently. Therefore, for the contact protection, the voltage and the current should be as low as shown in Table 2-3.
- An example of thermostat connection is shown in Fig.2-9.

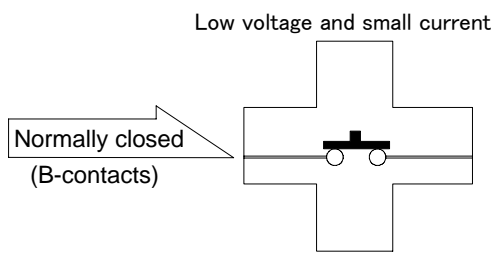

Fig.2-8 Thermostat Contacts

Table 2-2 Thermostat Operating Temperature

CLASS OF INSULATION	THERMOSTAT OPERATING TEMPERATURE
Class E	120 ± 5°C
Class F	155 ± 5°C
Class C	224 ± 5°C

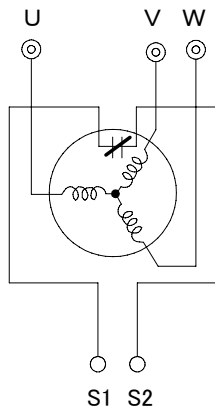

Fig.2-9 Standard Non-Seal Pump Motor Winding and Thermostat Connection Diagram (Example)

Table 2-3 Standard Thermostat Circuit Voltage and Current

AC100V	20~30mA
DC24~30V	10~25mA

- (3) After several months of pump operation, if the thermostat operates while the service conditions are not changed, it is indicative of contaminated jacket. Disassemble and clean the jacket. (Refer to Fig.2-10.) In such a case, periodical cleaning is necessary in general.

NOTE

Pump disassembly is necessary before inspection and washing of jacket.

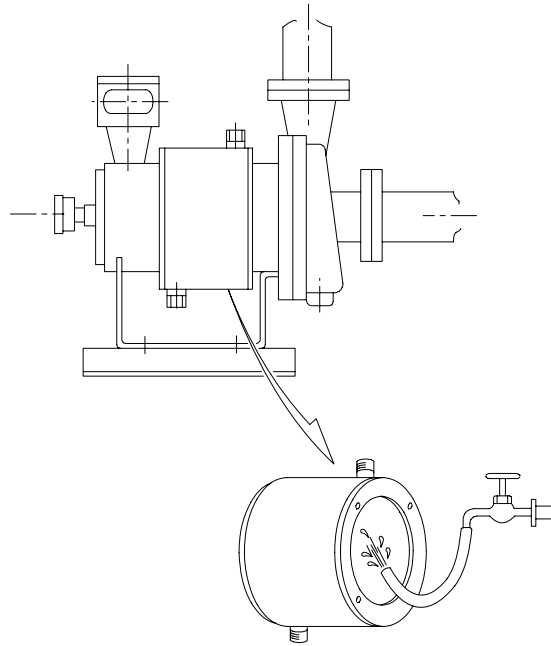

Fig.2-10 Check and Cleaning of the Jacket

2.8 Terminal Box and Resistance Measurement

2.8.1 Terminal Box

CAUTION

- (1) Do not use red painted terminals. (Refer to Fig.2-11.)
- (2) Do not disassemble the terminal assembly ③. Do not loosen the bolt ⑤.

Figs.2-13 to 2-16 show drawings of the Non-Seal pump standard terminal box.

- (1) Remove the cover from the terminal box, and the terminal ass’y will be visible.
- (2) The terminal ass’y and terminal symbols are as follows. (Refer to Table 2-4.)



Fig.2-11 Terminals not to be Used

Table 2-4 Terminal Ass’y and Terminal Symbols

For Drive Power	U, V, W
For Thermostat	S1, S2
For Spare	C1, C2

- (3) Lead-in port
Two ports for drive power and for thermostat are provided. The respective standard bore dimensions are as shown in Table 2-5.

Table 2-5 Standard Dimensions of Terminal Box Lead-In Ports

MOTOR FRAME NO.	FOR DRIVE POWER	FOR THERMOSTAT
H1, H2	G2 (PF2) 1 port	G3/4 (PF3/4) 1 port
J1, J2, J3, J4	G3 (PF3) 2 ports	
K1, K2, K3, K4		

2.8.2 E-MONITOR Terminal Box

⚠ CAUTION

- (1) Do not disassemble the terminal assembly ④. Do not loosen the bolt ⑦.
- (2) Before starting motor withstand voltage test, remove the E-MONITOR power supply cable (X-section in Figs. 2-15, 16) from the motor power terminal.
- (3) The power terminal box and the E-MONITOR terminal box are separated for models of J1 to J4 and K1 to K4. The power terminal box and the E-MONITOR terminal box are integrated into one unit for models of H1 and H2.
- (4) Do not remove the waterproof cover.
- (5) E-MONITOR consists of many electronic parts such as an electrolytic capacitor, which has inevitable age deterioration. As the lifetime of electronic parts is greatly dependent on the service environment of the pump, expected replacement interval of E-MONITOR assembly would be approximately five to ten years.

- (1) Remove the assembly Cover A of the terminal box and a terminal block will be exposed (Refer to Fig. 2-12).
- (2) The terminal block uses terminal symbols as listed below (Refer to Table 2-6).

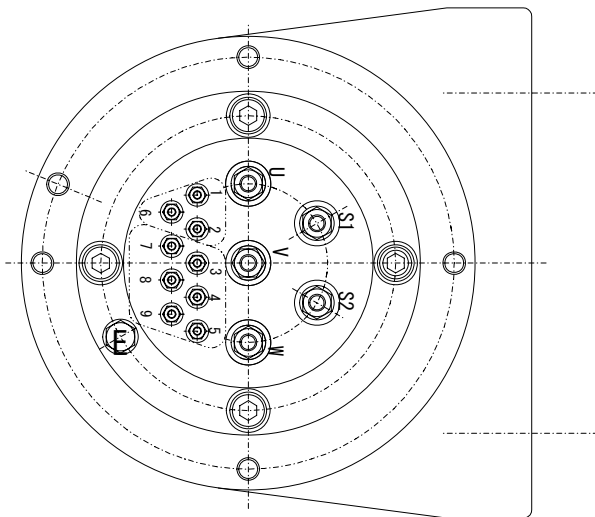
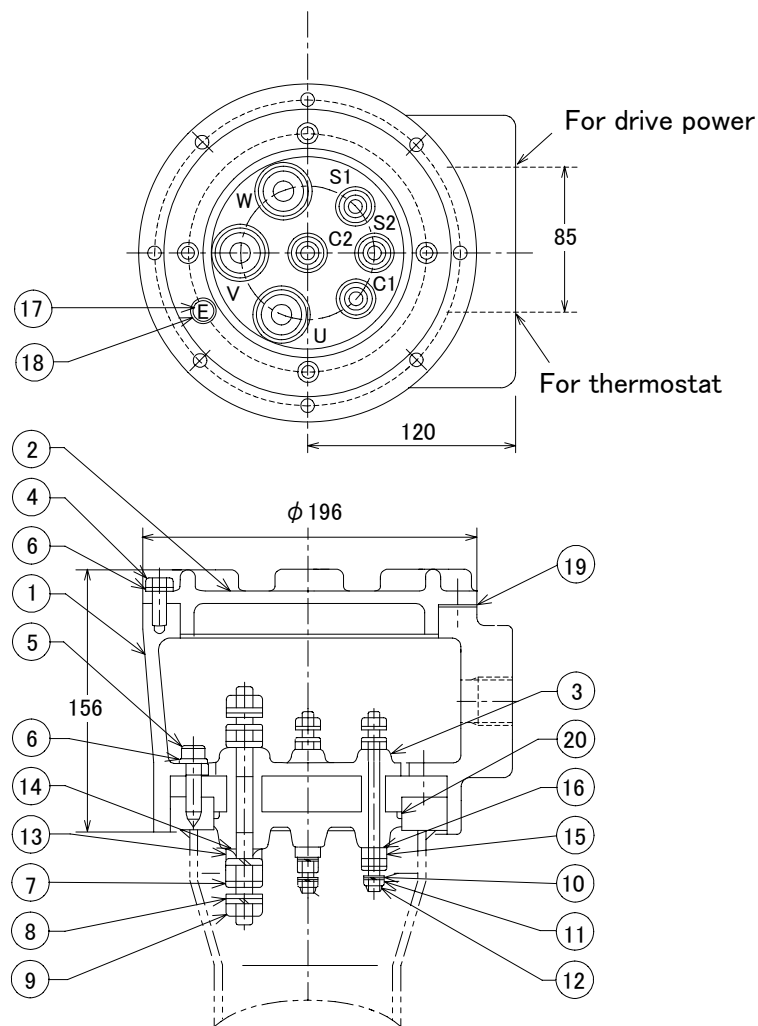

Table 2-6 Terminal Symbols in the Terminal Block

Item	Terminal symbol
For Power and E monitor power supply (M6)	U, V, W
Thermostat output (M6)	S1, S2
Detection coil output (M3)	3, 4, 5, 7, 8, 9
E monitor output (M3)	1, 2, 6

Fig. 2-12 E-MONITOR Terminal Block

Terminal box parts list (Frame H)



**Fig.2-13 Flameproof Type of Explosion-Protection Terminal Box
(Motor frame No. H1, H2)**

NO.	NAME	MATERIAL	Q'TY	REMARKS	NO.	NAME	MATERIAL	Q'TY	REMARKS
1	Main body	FC250	1		11	Spring washer	SWRH	12	For M6
2	Cover	FC250	1		12	Nut	BSBM/Ni	16	M6
3	Terminal assembly	_____	1		13	Washer	BSBM/Ni	3	
4	Bolt	S25C	8	M8	14	Gasket	Fluororubber	3	
5	Bolt	SCM435	4	M8	15	Washer	BSBM/Ni	4	
6	Spring washer	SWRH	12	For M8	16	Gasket	Fluororubber	4	
7	Plain washer	BSBM/Ni	15	For M12	17	Bolt	BSBM/Ni	1	M6
8	Spring washer	SWRH	9	For M12	18	Plain washer	BSBM/Ni	1	For M6
9	Nut	BSBM/Ni	12	M12	19	Gasket	Non-asbestos	1	
10	Plain washer	BSBM/Ni	20	For M6	20	Gasket	Fluororubber	1	

Terminal box parts list (Frame J, K)

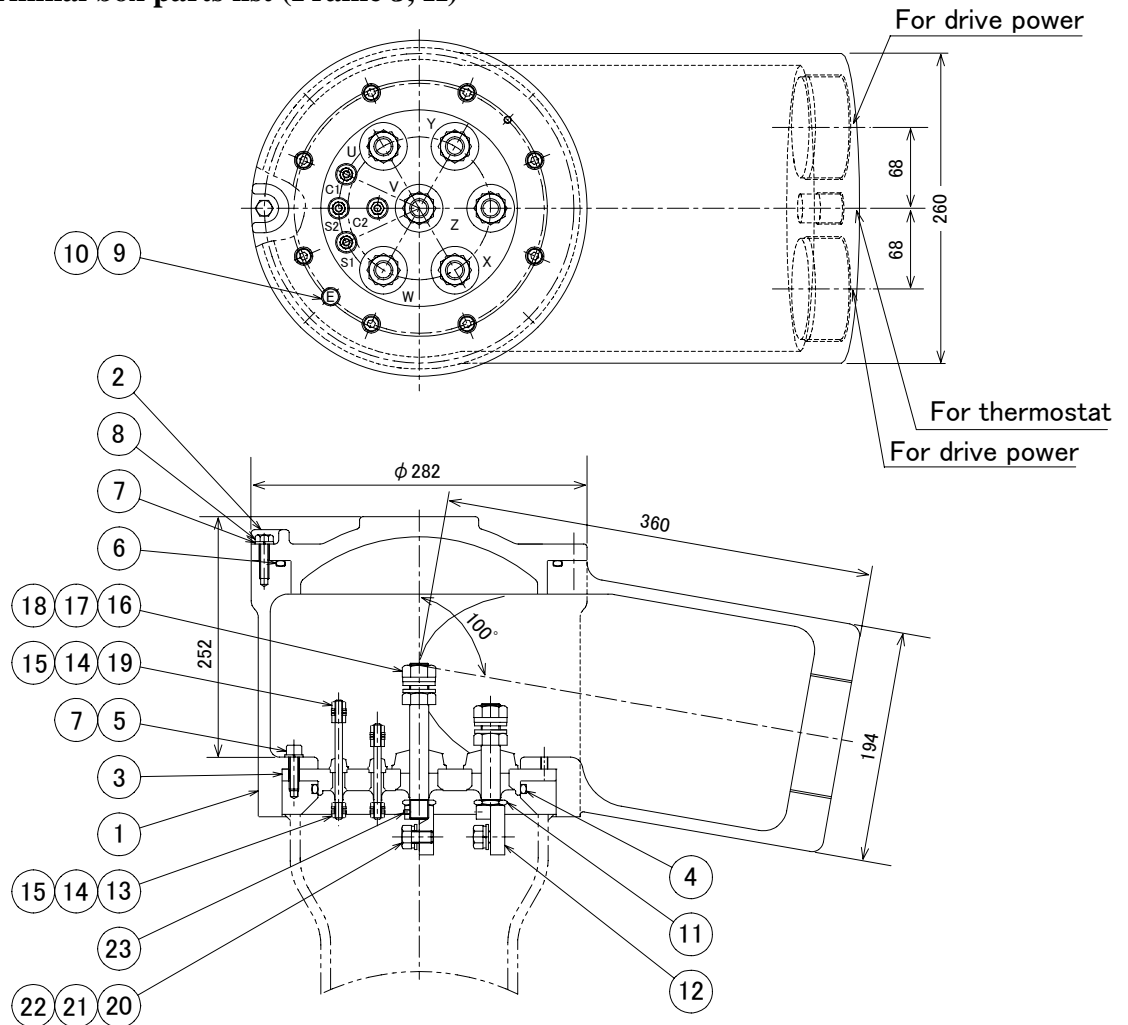
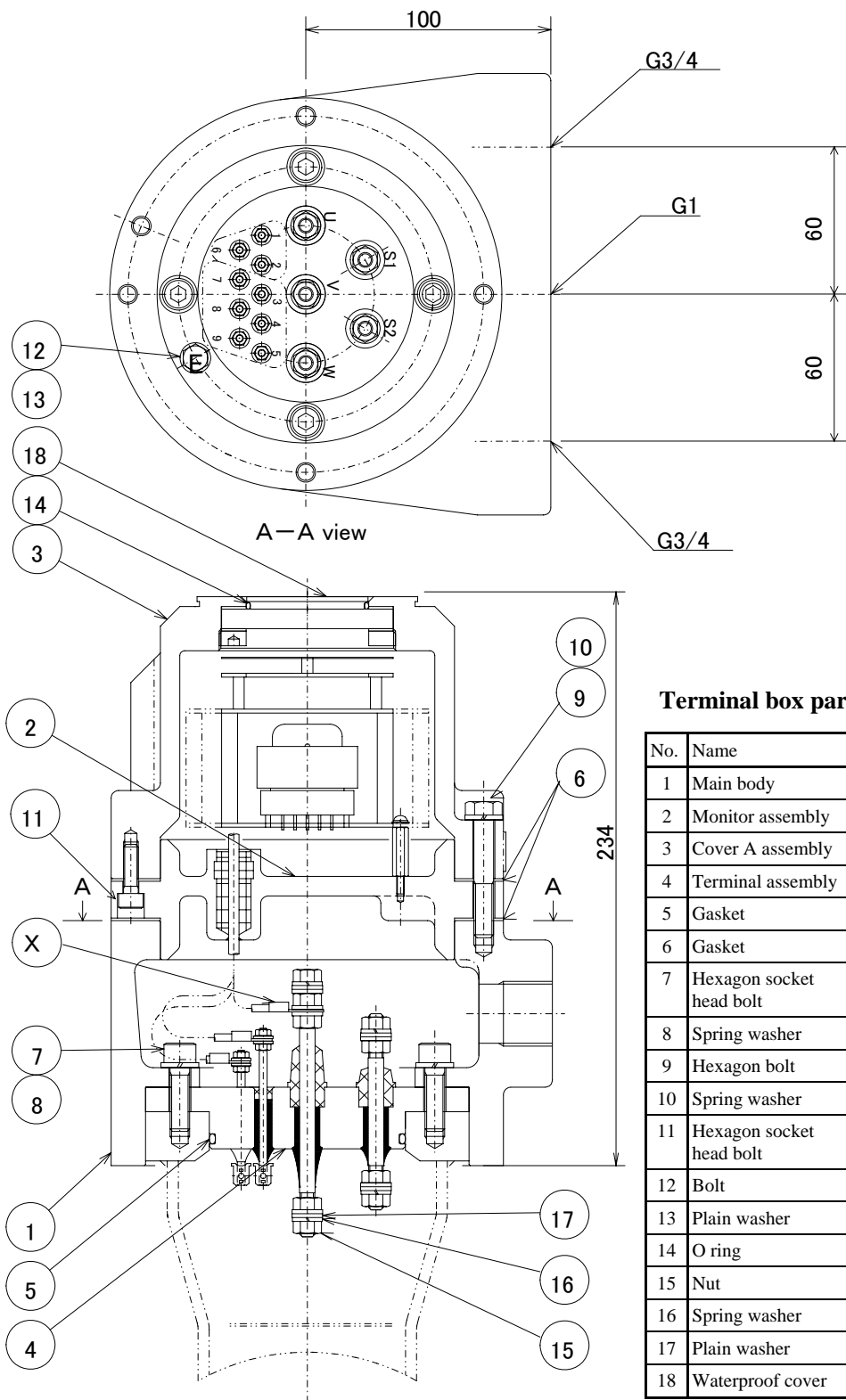

Fig.2-14 Flameproof Type of Explosion-protection Terminal Box
(Motor frame No. J1~J4, K1~K4)

NO.	NAME	MATERIAL	Q'TY	REMARKS	NO.	NAME	MATERIAL	Q'TY	REMARKS
1	Main body	FC250	1		13	Nut	BSBM	8	For M6
2	Cover	FC250	1		14	Plain washer	BSBM	16	For M6
3	Terminal assembly	————	1		15	Spring washer	SWRH	8	For M6
4	Gasket	Fluororubber	1		16	Nut	BSBM/Ni	12	For M16
5	Bolt	SCM435	8	M8	17	Plain washer	BSBM/Ni	12	For M16
6	Gasket	Fluororubber	1		18	Spring washer	SWRH/Ni	6	For M16
7	Spring washer	SWRH	16	For M8	19	Nut	BSBM	8	For M6
8	Bolt	S25C	8	M8	20	Bolt	BSBM/Ni	6	M10
9	Bolt	BSBM	1	M6	21	Spring washer	SWRH/Ni	6	For M10
10	Plain washer	BSBM	1	For M6	22	Plain washer	BSBM/Ni	6	For M10
11	Nut	C1100/N1	6	For M16	23	Set Screw	SCM435	6	M4
12	Nut	C1100/N1	6	For M16					

2 Installation and Piping



Terminal box parts list (frame J,K)

No.	Name	Material	Qty	Remarks
1	Main body	FC250	1	
2	Monitor assembly	ADC12/heat-resistant PVC	1	
3	Cover A assembly	ADC12/temperd glass	1	
4	Terminal assembly	SS400/glass	1	
5	Gasket	FR1	1	
6	Gasket	V6500	2	
7	Hexagon socket head bolt	SCM435-H	4	
8	Spring washer	SWRH/NI	8	For M8
9	Hexagon bolt	SS400/CM	4	M8
10	Spring washer	SWRH	4	For M8
11	Hexagon socket head bolt	SCM435-H	4	M6
12	Bolt	C3604BD	1	M6
13	Plain washer	C3604BD	27	For M6
14	O ring	Silicone rubber	1	
15	Nut	C3604BD	23	For M6
16	Spring washer	SWRH/NI	10	For M6
17	Plain washer	C3604BD	10	For M6
18	Waterproof cover	Acrylic plate	1	

Fig. 2-15 Flameproof Type of Explosion-protection Terminal Box (for E-MONITOR) (Motor frame No. J1~J4, K1~K4)

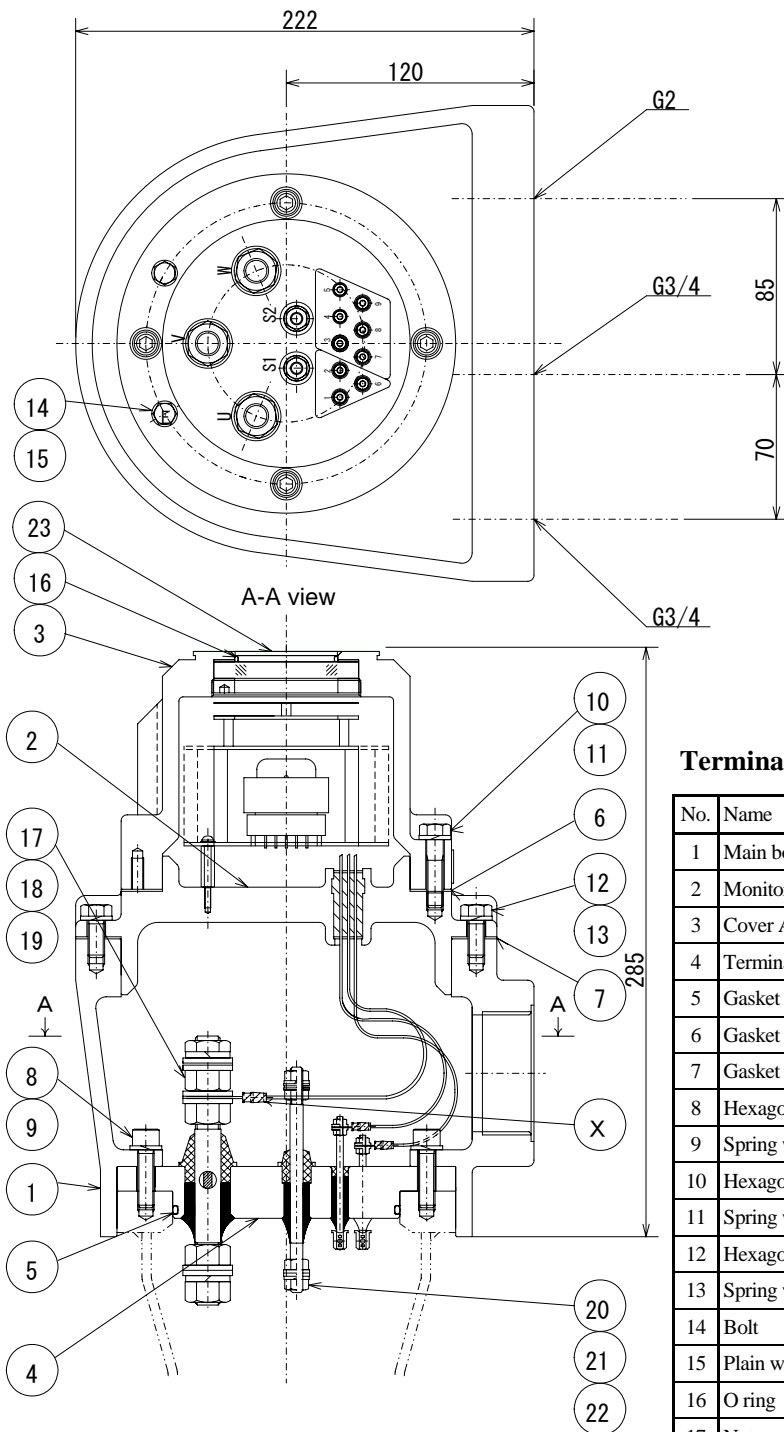

Terminal box parts list (frame H)

No.	Name	Material	Qty	Remarks
1	Main body	FC250	1	
2	Monitor assembly	FC250/heat-resistant PVC	1	
3	Cover A assembly	ADC12/tempered glass	1	
4	Terminal assembly	SS400/glass	1	
5	Gasket	FRI	1	
6	Gasket	V6500	1	T=1
7	Gasket	V6500	1	T=1
8	Hexagon socket head bolt	SCM435-H	4	M8
9	Spring washer	SWRH	4	For M8
10	Hexagon bolt	SS400/CM	4	M8
11	Spring washer	SWRH	4	For M8
12	Hexagon bolt	SS400/CM	8	M8
13	Spring washer	SWRH	8	For M8
14	Bolt	C3604BD	1	M6
15	Plain washer	C3604BD	1	For M6
16	O ring	Silicone rubber	1	
17	Nut	C3604BD	15	For M12
18	Spring washer	SWRH/NI	6	For M12
19	Plain washer	C3604BD	18	For M12
20	Nut	C3604BD	8	For M6
21	Spring washer	SWRH/NI	4	For M6
22	Plain washer	C3604BD	8	For M6
23	Waterproof cover	Acrylic plate	1	

Fig. 2-16 Flameproof Type of Explosion-protection Terminal Box (for E-MONITOR) (Motor frame No. H1,H2)

2 Installation and Piping

2.8.3 Check of Insulation Resistance

Before making wirings, measure the insulation resistance with a 500V megger at the following points.

- (1) Insulation resistance to be measured between
 - ① Stator winding and ground
 - ② Thermostat and ground
 - ③ Thermostat and stator winding
- (2) The allowable insulation resistance value is 2 M Ω .

NOTE

The pump is shipped with its allowable insulation resistance set to 100 M Ω or more.

2.8.4 Measurement of Winding Resistance

- (1) In the event that the overload relay or the thermostat operates and the motor in operation stops, investigate the cause before attempting to restart. After removal of the cause, measure the motor insulation and winding resistance.

WARNING

If the winding resistance is unbalanced more than $\pm 5\%$ between three phases, there is a possibility that a layer short-circuit has occurred. Never attempt to restart. (Refer to Fig.2-17.)

If the current is applied again to the motor before the layer short-circuited is removed, there is a danger of electric shock.

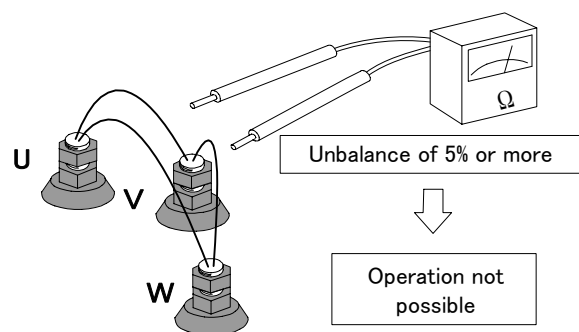

Fig.2-17 Measurement of Winding Resistance

- (2) Before measuring the winding resistance, clean the terminals thoroughly. Otherwise, defective connections at the terminal part will lead to measurement errors. Repeat the measurement several times to confirm that the winding resistance is correctly measured. (Refer to Fig.2-18.)

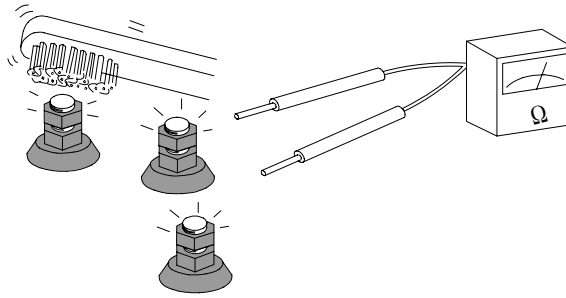

Fig.2-18 Winding Resistance Measuring Method

2.9 Connections

⚠ WARNING

A ground terminal is provided in the terminal box. By making use of this terminal, make grounding connection without fail. Otherwise, there is a danger of electric shock.

- (1) If the direction of phase rotation of power supply (R→S→T) is clear, make connections like R-U, S-V and T-W. (Refer to Fig.2-19.)
- (2) If the direction of phase rotation of power supply is not clear, confirm the direction of rotation in “3.1 Items to be confirmed before Operation”.

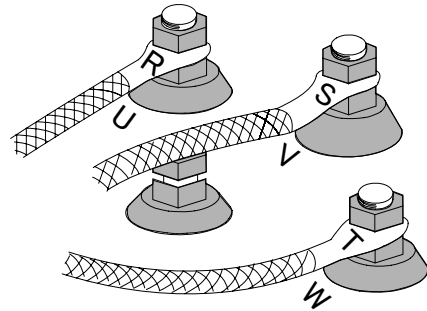

Fig.2-19 Power Supply Phases and Terminal Connections

- (3) When making electrical connections, take care to avoid ingress of rainwater. Fig.2-20 shows an example where an explosion-proof flexible hose (made of metal) is used.

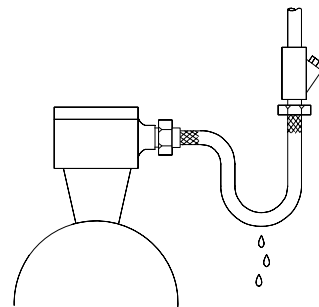

Fig.2-20 An Example Where an Explosion-Proof Flexible Hose is Used

⚠ CAUTION

- (1) Even if electrical wiring is completed, do not immediately start operation. (Start the pump according to Section 3 "Operation".)
- (2) If the pump is used outdoors, take care that water does not enter through the cover of the terminal box or lead-in port.

3 Operation

⚠ CAUTION

Do not operate the Non-Seal pump dry. (Refer to Fig.3-1.)
Dry operation may make the bearing portion unusable within a short time.

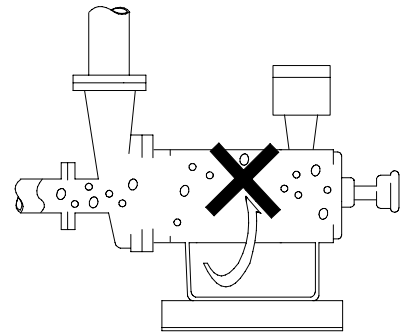

Fig.3-1 Prohibition of Dry Operation

⚠ CAUTION

Do not operate the pump shutoff for more than 1 minute. (Refer to Fig.3-2.)
Shutoff operation may damage the motor or make its bearing unusable.

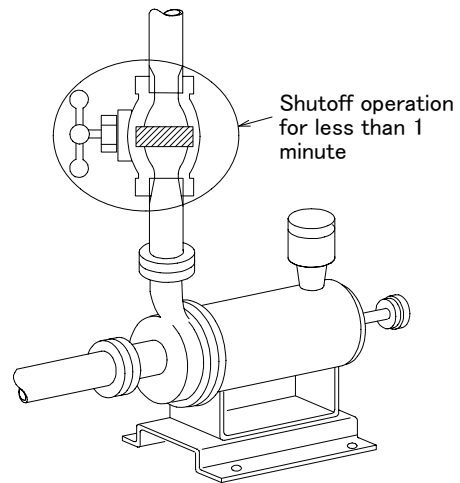

Fig.3-2 Prohibition of Shutoff Operation

3.1 Items to be Confirmed Before Operation

Before operation, confirm the following items.

3.1.1 Direction of Motor Rotation

It is normal that the standard Non-Seal pump should rotate counterclockwise as viewed from the pump side or clockwise as viewed from the motor side.

The direction of motor rotation should coincide with the arrow marked on the casing. (Refer to Fig.3-3.)

If a “Rotation Direction Detector” (optional) is used, the direction of motor rotation can be confirmed easily from the outside.

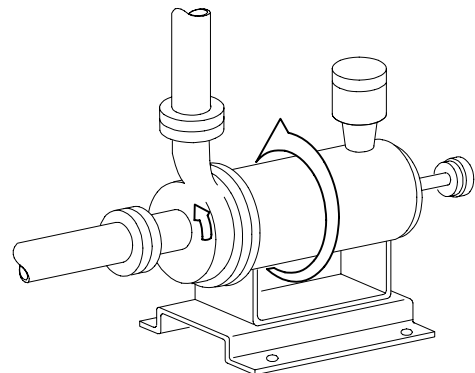

Fig.3-3 Direction of Motor Rotation

CAUTION

Never rotate the Non-Seal pump for more than 30 seconds in the reverse direction. (Refer to Fig.3-4.)

In the reverse rotation, the pump will not only fail to produce normal pump head and flow, but also cause cavitation or cause abnormal thrusts due to loss of the automatic thrust balancing function. As a result, the bearing may be abnormally worn out and the bolts be loosened due to vibration, possibly damaging the pump or leading to a fault.

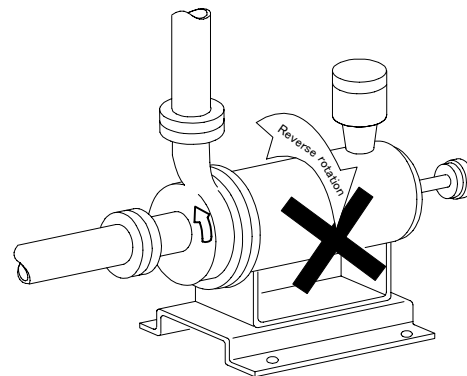

Fig.3-4 Prohibition of Reverse Rotation of Motor

3.1.2 Confirmation of Direction of Rotation (1)

After completing all preparations before operation and completing liquid application and jogging (Refer to 3.2), confirm the direction of rotation. For this confirmation, a NIKKISO rotation direction detector can be used.

For the operation of the rotation direction detector, refer to the appropriate instruction manual.

3.1.3 Confirmation of Direction of Rotation (2)

The direction of motor rotation is indicated by the discharge head of pump. That is, if the head at shutoff (flow 0) goes below 60~70% of the shutoff head shown in the test report and when the discharge valve is opened progressively, the discharge pressure rapidly decreases, it indicates reverse rotation. In such a case, promptly stop pump operation and correct it to the normal direction of rotation. (Refer to Fig.3-5.)

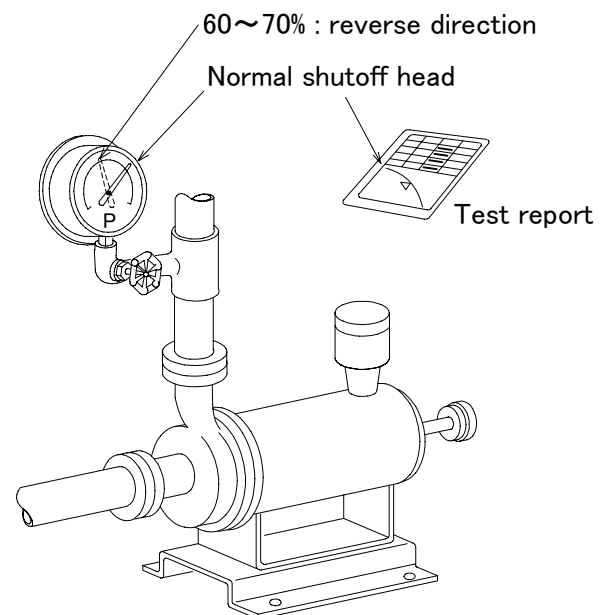

Fig.3-5 Confirmation of Direction of Motor Rotation

3.1.4 Check of Bearing Monitor (In the Case of Mechanical Type)

Confirm that the pointer of the bearing monitor is not in the red region. If it is in the red region, the bearing is abnormal.

For the details, refer to “4.4.1 Mechanical Type Bearing Monitor”.

3.2 Starting

3.2.1 Preparations for Starting

- (1) Close discharge and suction valves completely.
- (2) If the pump has a cooling water system, run cooling water or brine through the jacket.
(Refer to Fig.3-6.)

For the quantity of cooling water, refer to Table 2-1 in 2.5.1. This table refers to the case where industrial water of below 35°C is used.

- (3) Fully open the suction valve to fill the inside and the suction piping system with liquid.

In the Non-Seal pump, liquid enters even into the rotor chamber of the motor. (Refer to Fig.3-7.)

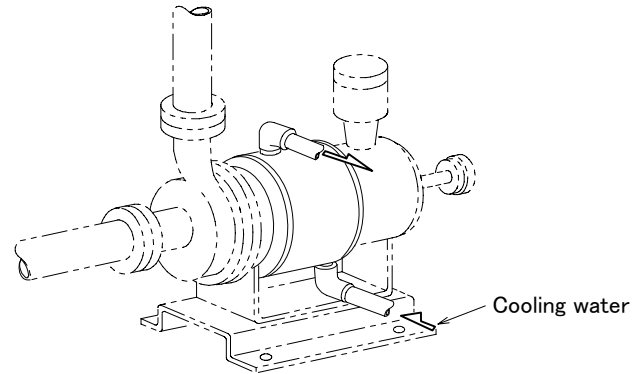

Fig.3-6 Water Application into Jacket

CAUTION

If the temperature of the liquid to be handled by the pump is below 0°C, leave the pump filled with liquid for more than 30 minutes to precool the pump sufficiently.

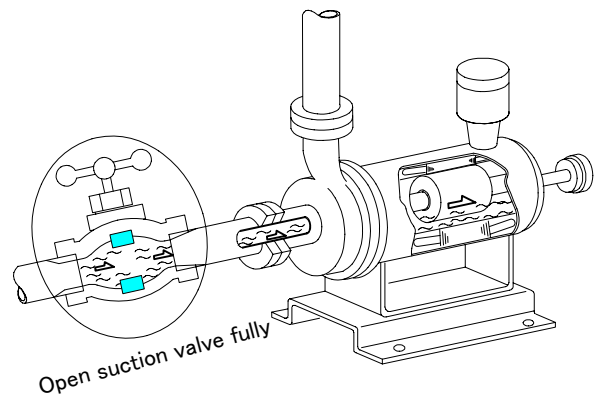

Fig.3-7 Air Venting of the Pump Inside

Then, slightly open the discharge valve and vent air of the pump inside positively.

WARNING

Open the air vent valve and vent air sufficiently. In the case of a combustible or toxic liquid, provide a vent piping to introduce the liquid into a safe place.
(Refer to Fig.3-8.)

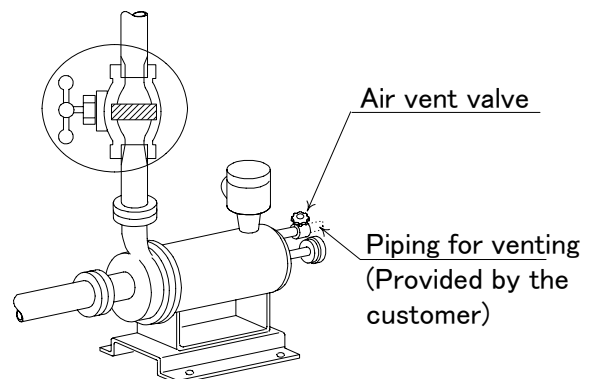

Fig.3-8 Air Venting

CAUTION

Close the discharge valve completely, and at the intervals of about 30 seconds, jog the pump three times. At each jogging, open the discharge valve and the air vent valve, so as to perform air venting. (Refer to Fig.3-9.)

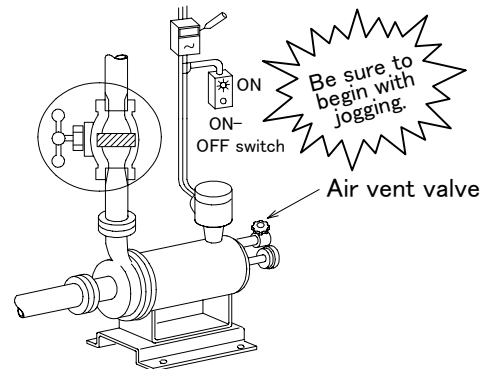

Fig.3-9 Jogging

“Jogging” means that the motor is applied with current for 2-3 seconds and then immediately stopped. During jogging, confirm that no abnormal sound or vibration occurs.

NOTE

If a liquid having a small specific gravity and a high vapor pressure is handled, there is a possibility that vapor locking occurs inside the pump. Therefore, with the discharge valve slightly open, start the pump. If a liquid having a vapor pressure of higher than 0.1MPa (1.0 kgf/cm²A) is handled, usually the reverse type Non-Seal pump is used. If the basic type pump is to be used when the vapor pressure is above 0.1MPa (1.0 kgf/cm²A), please contact the manufacturer beforehand.

3.2.2 Startup Procedure

- (1) Make sure no reverse pressure is applied and gradually open the discharge valve.
- (2) Air venting again of the pump inside
After pump operation of 10~20 seconds, close the discharge valve and stop the pump. Then, again carry out jogging and air venting three times repeatedly for complete air venting of the pump inside.
- (3) After completion of air venting, restart the pump. Check to see that the pressure gauge on the discharge side indicates the specified value, and gradually open the discharge valve to raise the discharge flow up to the service flow. (Refer to Fig.3-10.)
- (4) Note the pressure difference between the points before and after the strainer on the suction side.
If this pressure difference is increasing, it indicates that the strainer is clogged. Stop the pump and clean the strainer.
- (5) When the Non-Seal pump is in normal operation, it is very quiet and little vibration is produced.

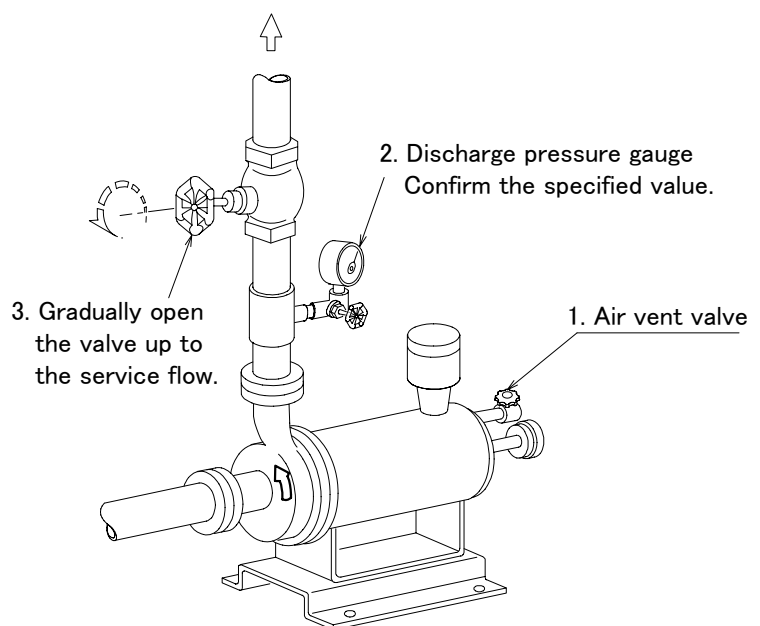

Fig.3-10 Startup of Pump

Check the pump in operation for the following points.

- ① Discharge flow and discharge pressure are as specified. (Refer to Fig.3-11.)
- ② There is no abnormal sound.
- ③ The pump produces no cavitation.

Open the discharge valve of the pump progressively. If the pump begins to produce sound and vibration at a certain flow, and even if the valve is further opened, it fails to increase the flow, it is indicated that cavitation occurs.

Take care to perform this operation only when necessary, and insure that the number of times is only one.

CAUTION

Never continue to operate the Non-Seal pump while it is producing cavitation. If it is continued to operate in this condition, the bearing will produce early wear.

- ④ The motor current does not exceed the rated current.
When the specific gravity and/or viscosity of the handled liquid exceeds the specification or the flow exceeds the required value, it may happen that the pump is overloaded. Take care to avoid overloading.
- ⑤ When the motor is operated with an excessive flow, it may happen that a vibrating sound is produced in the pump outlet, but this indicates no abnormality in the pump main body. In such a case, throttle the discharge valve to reduce the flow.
- ⑥ When starting the pump with a liquid of high viscosity at normal temperature, throttle the discharge valve and adjust the current to within the rated current limits.
- ⑦ If any abnormal symptom is found in the pump, immediately stop the pump. For the remedies, refer to “5.1 Troubleshooting”.

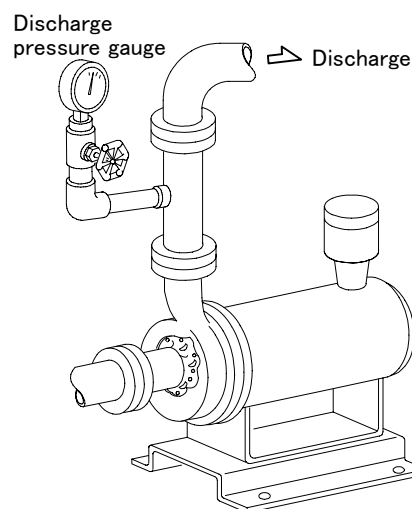

Fig.3-11 Confirmation of Operating Conditions

3.3 Stopping

3.3.1 Normal Stopping

Close the discharge side valve completely (or slightly open for the liquid having small specific gravity and high vapor pressure) and stop the motor as quickly as possible.

After stopping, close the suction valve.

Then, close cooling water and other auxiliary piping systems. (Refer to Fig.3-12.)

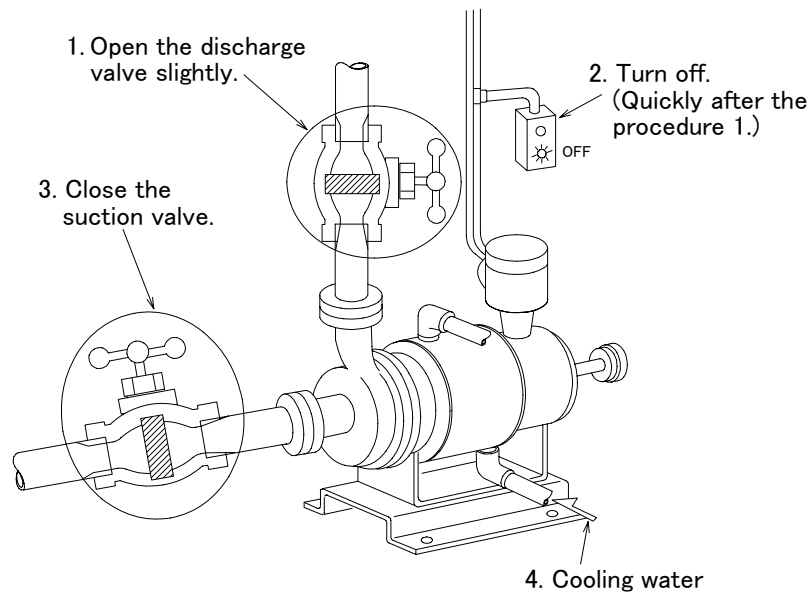

Fig.3-12 Pump Stopping Procedures

CAUTION

When the liquid having high temperature and/or high vapor pressure is handled, do not stop the cooling water system before the motor is cooled (for about 30 minutes).

If cooling is stopped before the motor is cooled, the bearing may be damaged upon restarting.

3.3.2 Long-Term Shutdown

If the pump is to be kept at shutdown for a long period (more than 1 week when the plant operation is stopped or more than 1 month when it is switched to the standby pump), drain out the handled liquid of the pump and the liquid of cooling water and other auxiliary systems. If there is a possibility of freezing in the winter season or the like, the pump not drained may be damaged.

3.3.3 Starting after a Long-term Shutdown

When starting the pump after a long-term shutdown, check the various pump portions and check motor insulation resistance, and thereafter, proceed similarly to the case of normal starting.

If the motor insulation resistance is low, but still is about $2M\Omega$, the motor may be started as it is. If the insulation resistance increases after some time of operation, the pump may be used as it is. (Refer to Fig.3-13.)

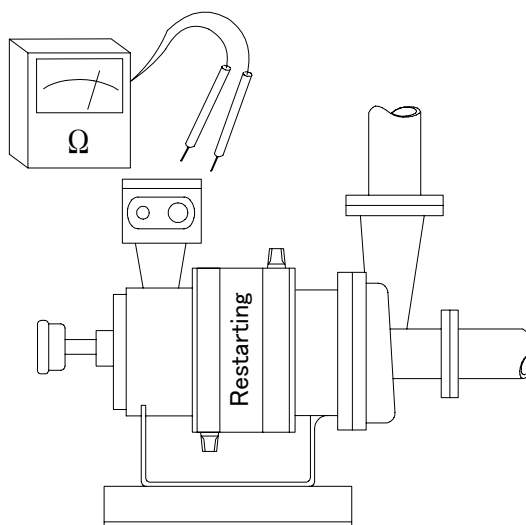

Fig.3-13 Starting after a Long-term Shutdown

3.4 Care During Steady-State Operation

⚠ CAUTION

During the operation or directly after stopping, never touch the motor outer wall by hand, as it may cause a burn on the hand.

For any pump where the motor outer wall temperature exceeds 100°C, a “Burn prevention cover” is available (optional).

3.4.1 Items to be Checked During Steady-State Operation

⚠ CAUTION

For each type pump, the minimum limit flow is specified as shown in Table 3-1. If the pump is operated with a flow below this value, it may happen that the motor is overheated or vibration occurs.

Table 3-1 Minimum Flow Rate

UMP NO.	MINIMUM FLOW (m ³ /h)	
	WITHOUT DISCHARGE ORIFICE	WITH DISCHARGE ORIFICE
46A 46B	50	50
47B 47C	100	100
47D	100	120
48C 48D	240	240

During steady-state operation, periodically check the following items.

- (1) There is no abnormal indication of the discharge pressure gauge.
(Refer to Fig.3-14.)
- (2) There is no overcurrent (overload), and the current value is not different from the steady-state value.
- (3) There is no abnormal sound. No vibration occurs. If any abnormal sound or vibration is found, it indicates, in general, that cavitation occurs or the bearing wears beyond the limit.
- (4) For any pump with a mechanical bearing monitor, the pointer of the monitor is not in the red region.
- (5) Temperature of the various pump portions
No portion is abnormally heated unlike before.
- (6) There is no abnormality in cooling water and other auxiliary systems.

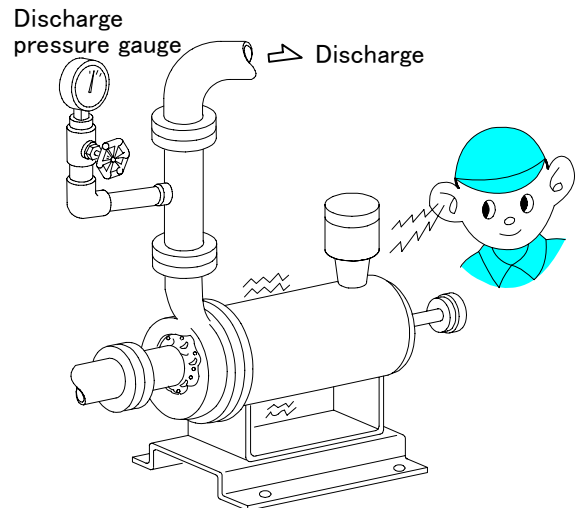

Fig.3-14 Check During Steady-state Operation

3.4.2 Emergency Stopping

When there is a thermostat circuit connected to the electromagnetic switch, the pump is automatically stopped when the motor winding temperature exceeds the specified value. The thermostat operates in the following cases.

- (1) Overheating due to abnormal handled liquid temperature or cooling system
 - (2) Overcurrent in the winding (overload)
- Moreover, the motor is stopped by the overcurrent relay due to the overload itself. Locate and remove the cause before attempting restarting. Moreover, check the motor itself by reference to “2.8 Terminal Box and Resistance Measurement”.

4 Check and Maintenance

4.1 Daily Check

⚠ CAUTION

If the pointer of the monitor is in the red region, immediately stop the pump. After motor stopping, disassemble and check the motor and confirm no significant wear of the bearing.

During steady-state operation, check the following items at least once a day.
(Refer to Fig.4-1.)

- (1) There is no abnormal indication of the discharge pressure gauge.
- (2) There is no overcurrent (overload), and the current value is not different from the steady-state value.
- (3) There is no abnormal sound. No vibration occurs. If any abnormal sound or vibration is found, it indicates, in general, that cavitation occurs or the bearing is worn out beyond the limit.
- (4) For any pump with a bearing monitor, the pointer of the monitor is not in the red region. (For the details, refer to “4.4 Bearing Monitor”.)
- (5) Temperature of the various pump portions
No portion is abnormally heated unlike before.
- (6) There is no abnormality in cooling water and other auxiliary systems.
- (7) There is no leaking portion.

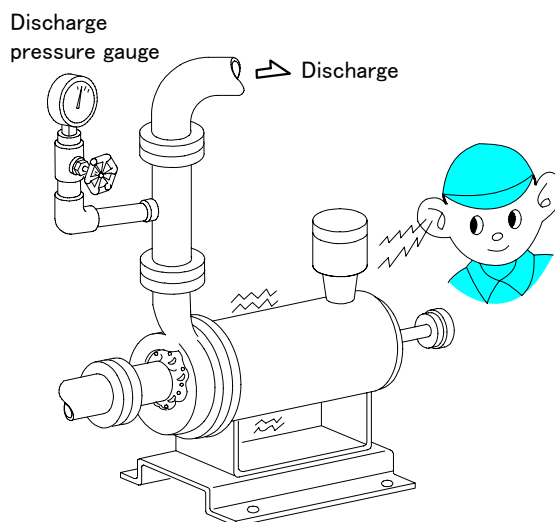

Fig.4-1 Daily Check

4.2 Method of Disassembly

The disassembling procedure is as follows.

The Part Nos. in the text correspond to the Part Nos. on the assembly sectional diagram in Fig.1-1 or Fig.1-2.

⚠ WARNING

Prior to attempting disassembly, drain out the liquid in the pump completely. Clean the inside of the pump if the handled liquid requires it. Otherwise, there may a danger of burn, eye damage, etc.

By proceeding with (1), (2), (3) and (4) in this section, the entire pump can be removed from the remaining base.

To disassemble the pump for checking the inside of the pumps, proceed with (1), (4) and (5) in this section.

⚠ WARNING

Before removing the electrical wirings of the motor, be sure to confirm that the motor power supply is turned off. Otherwise, there may be a danger of electric shock.

- (1) Apply marks U, V, W, S1, S2, etc. to the leads to be removed. After this marking, remove the motor wirings. (Refer to Fig.4-2.)

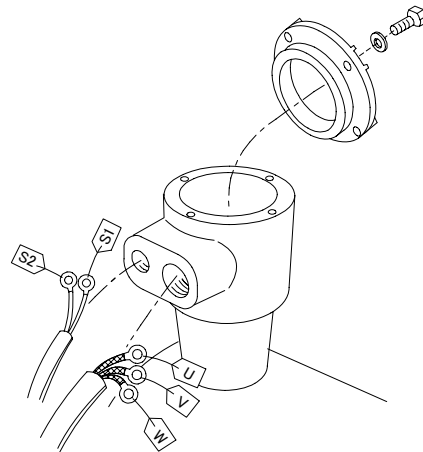

Fig.4-2 Marking to Electrical Wirings of the Motor

- (2) Remove auxiliary piping. (In the case where cooling water is used.) Disconnect the cooling water piping from the pump. On the cooling water piping thus removed, cover the pipe end to prevent ingress of dirt or dust. (Refer to Fig.4-3.)

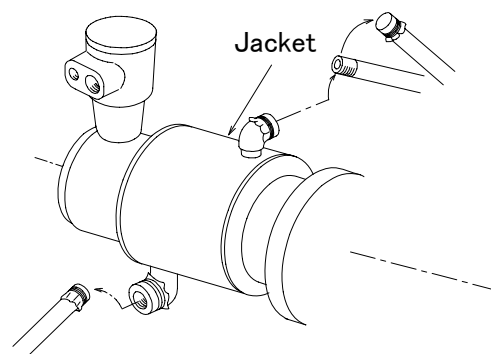

Fig.4-3 Removal of Auxiliary Piping

(3) Remove pump inlet and outlet pipings.

(4) Remove the pump and the base.

In the case of horizontal type, remove bolts (142) which connect the stand (S17) to the base (B05). (Refer to Fig.4-4.)

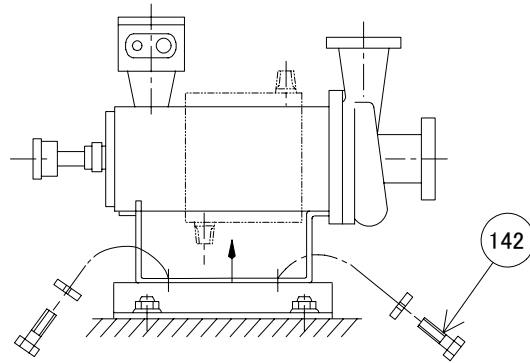

Fig.4-4 Removal of the Pump from the Base

(5) Remove pump casing mounting bolts (111), and the pump can be pulled off to the rear side. The casing (C20) remains on the pump inlet/outlet piping. (Refer to Fig.4-5.)

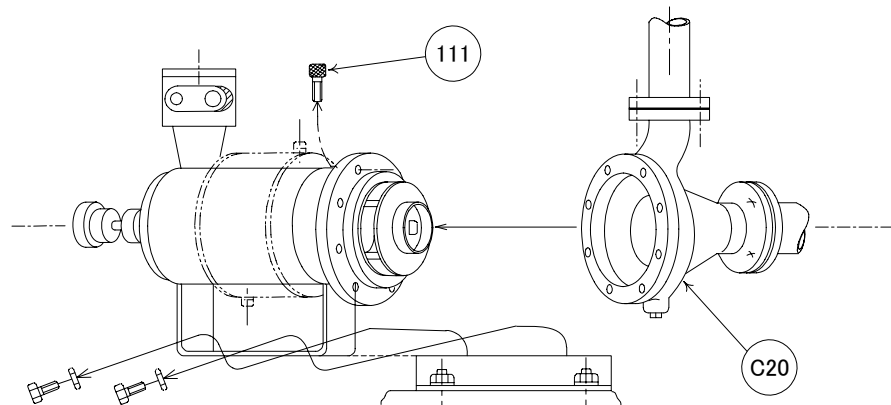

Fig.4-5 Removal of Stator Assembly Side

* When the disassembling procedure has progressed up to this point, the casing (C20) inside and the impeller (J12) can be checked. For checking the bearing (B012) and the rotor(R16) chamber inside, further proceed as follows.

4 Check and Maintenance

(6) Removal of impeller (Refer to Fig.4-6.)

Raise the bent portion of the washer assembly (W01A) and remove the impeller bolt (B20) provided at the end of the shaft(S03), and the impeller (J12) can be pulled out. When pulling out the impeller, take care not to bend the shaft by prying it out unreasonably, nor to miss the impeller bolt, washer assembly and key (K011). The washer assembly, once used, should not be reused, but be replaced with a new one.

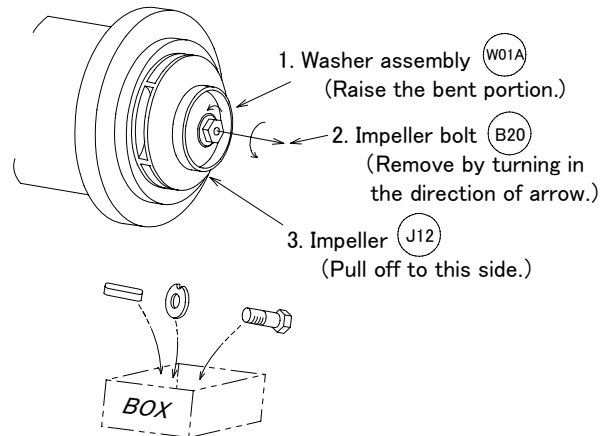

Fig.4-6 Removal of Impeller

(7) Removal of mechanical type bearing monitor (Refer to Fig.4-7.)

Loosen the nut [N02], tilt the bearing monitor and pull it out backward.

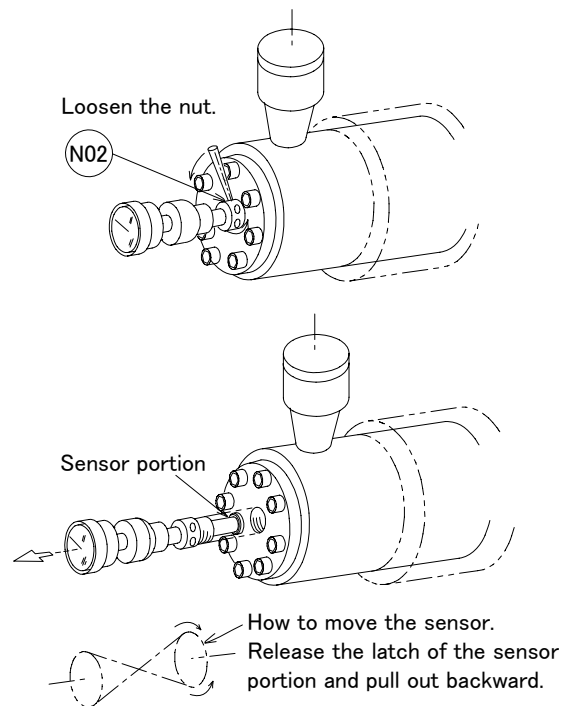

Fig.4-7 Removal of Mechanical Bearing Monitor

- (8) Removal of RB housing (Refer to Fig.4-8.)
Remove the bolt (224), and the RB housing (H14) comes off.

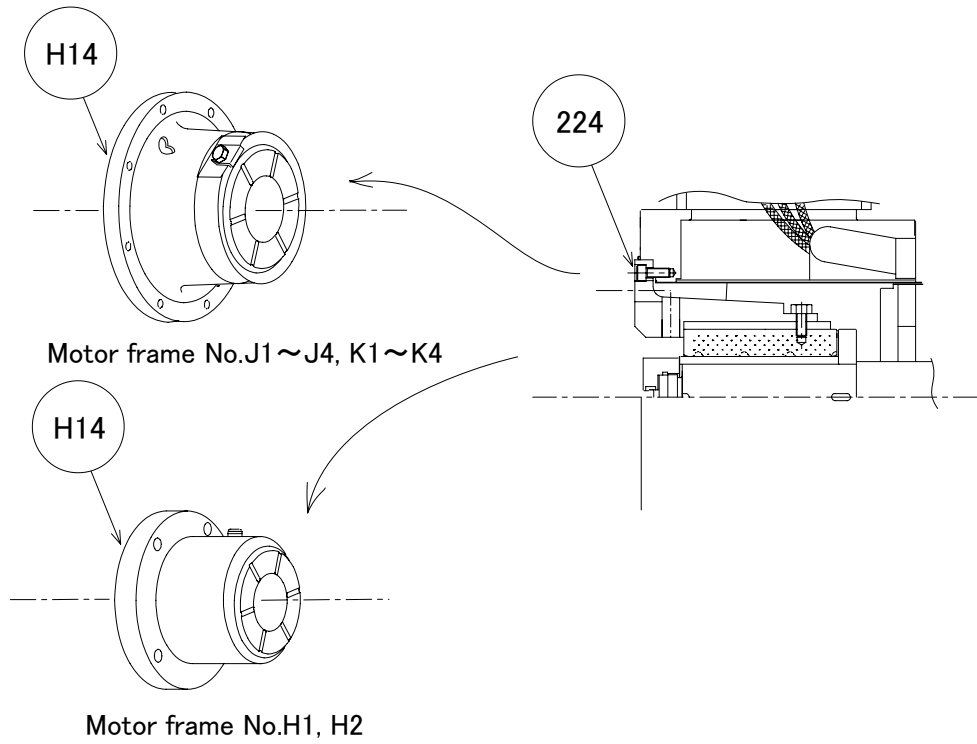

Fig.4-8 Removal of RB Housing

4 Check and Maintenance

(9) Removal of liner disk, adapter plate and FB housing (Refer to Fig.4-9)

- ① Remove bolt (222), and liner disk (D05) comes off.
- ② Remove bolt (212) and remove adapter plate (P22).
At this time, gasket (312) also comes off.
- ③ Remove bolt (221) and remove FB housing (H13).

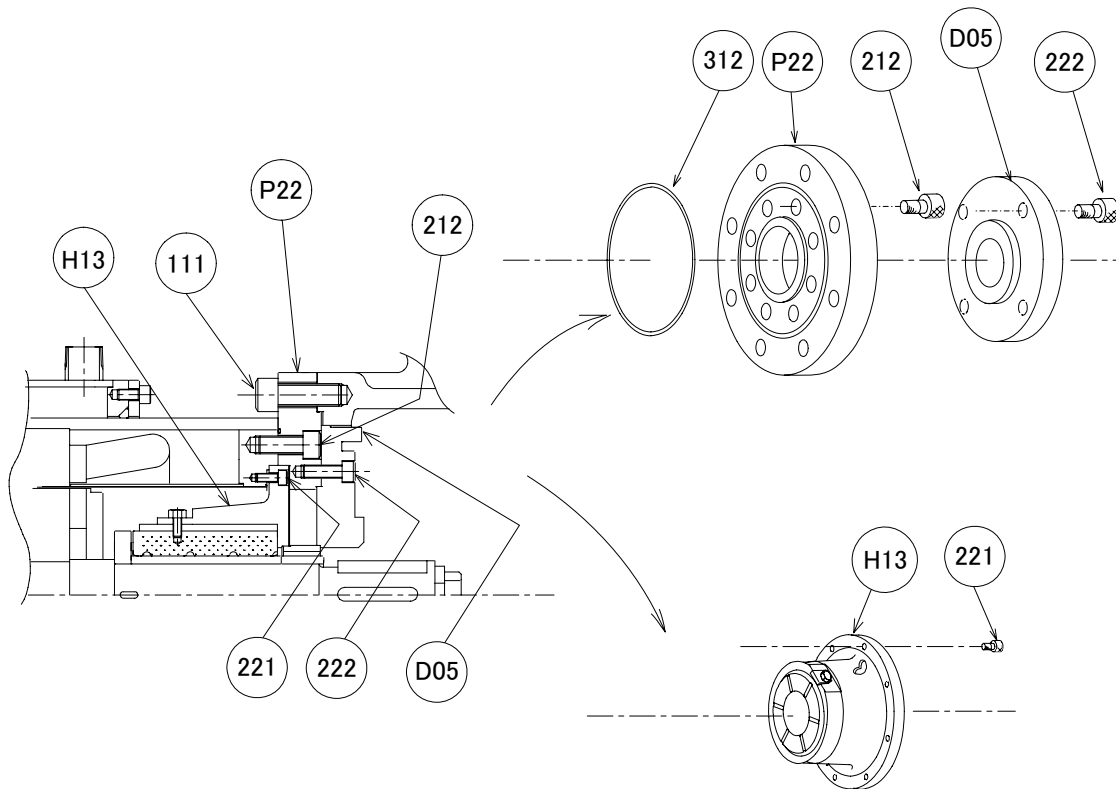

Fig.4-9 Removal of Liner Disk, Adapter Plate and FB Housing

(10) Pull-out of rotor assembly (R16)

After the procedure so far described, the rotor assembly (R16) can be pulled out to the back of the motor. When pulling out the rotor assembly, move it slowly and straightly to the back without applying any unreasonable force.

CAUTION

When removing the shaft sleeve (S30), loosen the end nut (N07) at the back of the shaft. This end nut has left-hand threads.

Loosen it by clockwise turning.
(Refer to Fig. 4-10.)

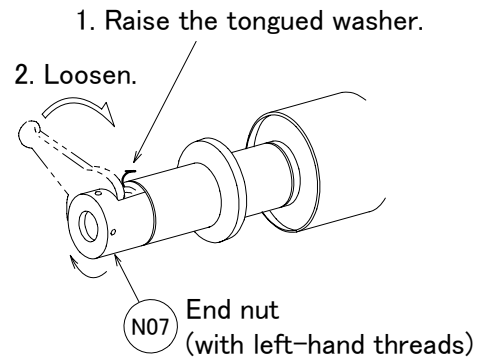

Fig.4-10 Removal of End Nut

- * In the normal case, the procedure for disassembly so far described is sufficient for the internal check.

4 Check and Maintenance

(11) Removal of jacket (Refer to Fig.4-11.)

After a long time of operation, for internal cleaning or replacement of the jacket (J01), proceed as follows.

Previously, the pump should have been disassembled in accordance with the paragraph of disassembly.

The jacket is fixed to the gasket (331) to the outer periphery of the stator assembly (S36). Remove the cover plate (P11) and pull out the gasket, and the jacket can be removed from the stator.

At this time, the gasket (331) is caught in the body of the jacket. Pull it off taking care not to damage.

If the gasket is badly deformed, replace it. The jacket, which has been disassembled and cleaned completely, should be promptly reassembled to the stator assembly (S36).

Take care to insure that the mounting position is the same as before disassembly.



Fig.4-11 Removal of Jacket

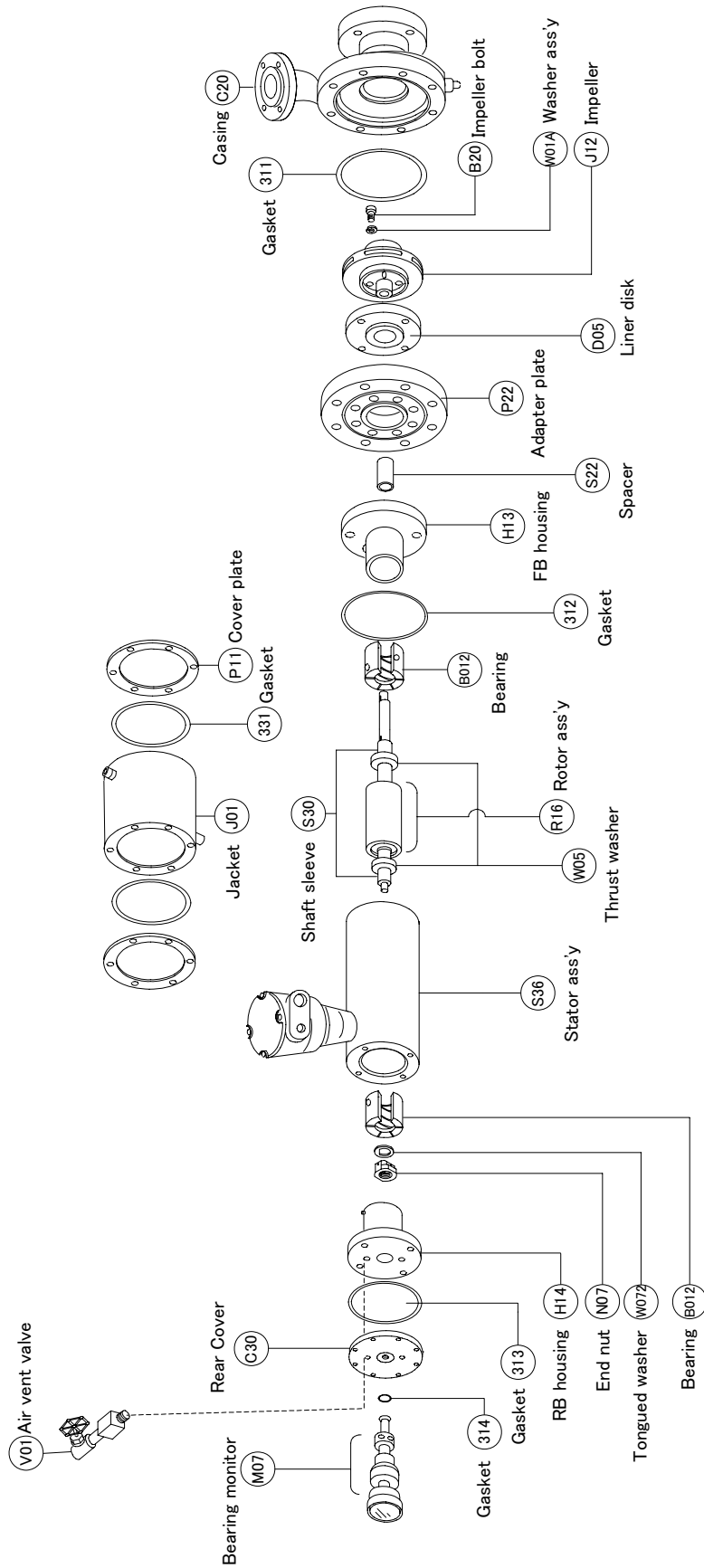

Fig.4-12 Basic Type Pump Disassembly

4.3 Check of Bearing

If the bearing is worn out beyond the wear limit, it may happen that the rotor sleeve and the stator liner come into contact with each other, causing the stator liner to be damaged.

Take adequate care in checking the bearing during the operation.

The bearing (B012), together with the shaft sleeve (S30), receives radial loads, and, together with the thrust washer (W05), thrust loads.

4.3.1 Life of Bearing

The bearing is used in the handled liquid. Depending on the properties, temperature, etc. of the liquid, the bearing endures continuous operation of one year or more (about 8,500 hours) if the liquid has the properties approximately equal to water. However, depending on the liquid and service conditions, the life may be less than one year. In such a case, the bearing should be checked not once a year but at reduced intervals according to the life.

At any time when an abnormal vibration or sound is generated during the operation, and at the time of periodical check, be sure to disassemble the pump and check the bearing.

For the wear limit which requires bearing replacement, refer to Fig.4-13 and Table 4-1.

NOTE

When the bearing is replaced, check the shaft sleeve and the thrust washer.

If either part is damaged on its surface, immediately replace it with a new one.

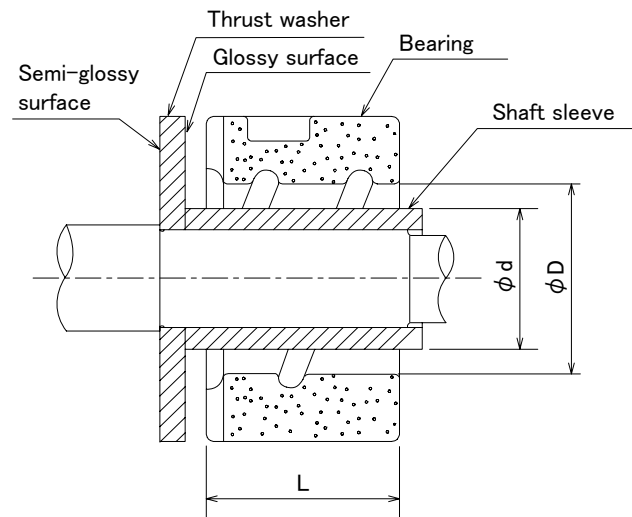

Fig.4-13 Illustration of Bearing Wear Limits

Table 4-1 Table of Bearing Wear Limits Unit : mm

MOTOR FRAME NO.	$\phi D - \phi d$	TOTAL LENGTH L, MINIMUM VALUE	
		FRONT SIDE	REAR SIDE
H1, H2	0.5	104.5	105.2
J1, J2, J3, J4	0.6	129	129.7
K1, K2, K3, K4	0.6	140	140.7

4.4 Bearing Monitor

The bearing monitor is used for the following purposes.

- ① Early detection of abnormal bearing wear
- ② Early detection of rotor sleeve and stator liner corrosion

4.4.1 Mechanical Type Bearing Monitor

For the mechanical bearing monitor Type No. and specifications, refer to Table 4-2.

Table 4-2 Bearing Monitor Type No. and Specifications

BEARING MONITOR TYPE NO.	MATERIAL	PUMP SUCTION PRESSURE	MONITOR PRESSURE RESISTANCE
MS-01 (MS-11)		Not larger than 0.245MPa (Not larger than 2.5kgf/cm ² G)	2.0MPa (20kgf/cm ² G)
MS-02 (MS-12)	SUS16 (standard) CA20 (special) HC (special)	Larger than 0.245MPa, not larger than 2.0MPa (Larger than 2.5kgf/cm ² G, not larger than 20kgf/cm ² G)	
MS-03 (MS-13)		Larger than 0.735MPa, not larger than 5.0MPa (Larger than 7.5kgf/cm ² G, not larger than 50kgf/cm ² G)	5.0MPa (50kgf/cm ² G)

NOTE : The bearing monitor of Type No. shown within parentheses has the gauge facing sideways and, otherwise, is of the same specifications.

- (1) Construction (Refer to Fig.4-14)

The bearing monitor consists of a gauge to alarm a hazard and a pressure-sealed sensor portion. In the case of Type MS-01, argon gas is sealed at about 0.98~1.18MPa (10-12 kgf/cm²G), while in the case of Type MS-02 or MS-03, at the atmospheric pressure.

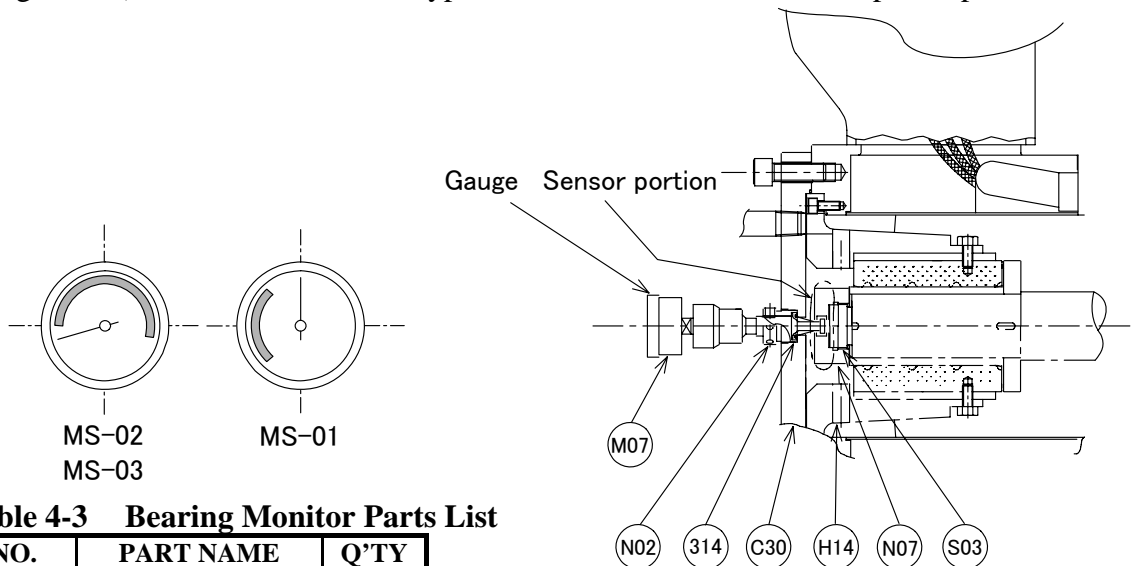

Table 4-3 Bearing Monitor Parts List

NO.	PART NAME	Q'TY
C30	Rear cover	1
H14	RB housing	1
M07	Bearing monitor	1
N07	End nut	1
S03	Shaft	1
314	Gasket	1
N02	Nut	1

Fig.4-14 Bearing Monitor

(2) Operation

If the bearing wears abnormally, or the rotor sleeve (S29) or stator liner (L05) corrodes abnormally, while the pump is in operation, then the sensor portion is broken and in the case of Type MS-01, the sealed argon gas is discharged and as a consequence, the pressure in the gauge lowers and the pointer indicates the red region showing a hazard.

In the case of Type MS-02 or 03, the pressure inside the pump enters through the broken sensor portion and as a consequence, the pressure inside the gauge rises and the pointer indicates the red region showing a hazard. (Refer to Fig.4-15.)

Type markings MS-01, MS-02 and MS-03 are printed inside the gauge.

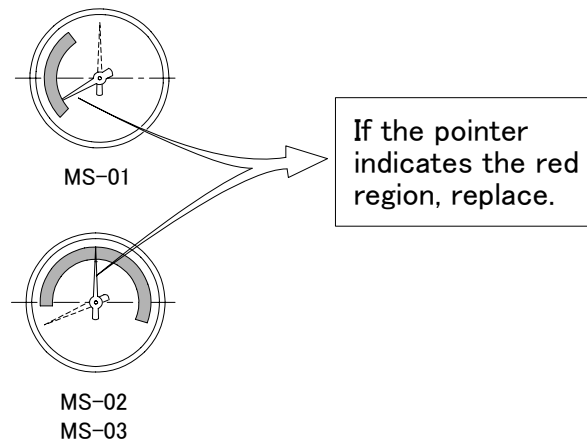

Fig.4-15 Indicating Portion of the Bearing Monitor

(3) Time of bearing replacement, and check of rotor sleeve and stator liner for whether to continue use or not

Check the pointer of the gauge of the bearing monitor. If the pointer is in the red region, check the bearing for wear, the rotor sleeve and stator liner for corrosion, and the sensor portion for fracture or corrosion.

- ① In the case of Type MS-01, if an abnormal condition occurs, that is, the bearing monitor operates, either with the pump in operation or at rest, the pointer indicates the red region.
- ② In the case of Type MS-02 or 03, if an abnormal condition occurs, that is, the bearing monitor operates, the pointer indicates the red region of the pump suction pressure. However, even if the bearing monitor has once operated, the pointer comes off the red region if the pump suction pressure lowers when the pump is stopped or disassembled.

If the bearing monitor has once operated, replace the end nut (N07), the complete set of bearing monitor, and the gasket (314) with new ones. Gasket (314), once used, should not be reused.

(4) Mounting and removal

Into the hole drilled in an eccentric position on the end nut (N07), insert the end of the sensor portion of the monitor in an inclined position and then tighten the nut (N02) taking care not to pry. This completes mounting.

For the method of removal, refer to “4.2 Method of Disassembly”.

4.4.2 E-MONITOR

If the bearing is worn, causing the rotor to rotate off-center or shifted axially, a voltage proportional to the eccentricity or degree of wear is produced at the sensor embedded in the stator. The voltage produced indicates the condition of bearing wear on the E-MONITOR display section.

(1) Field type

An E-MONITOR display section is mounted on the terminal box of the pump main unit. The pump main unit and the E-MONITOR display section are supplied with wiring already connected.

The E-MONITOR is provided with an output terminal (DC0-5V/4-20 mA/RS422) on the option. See Fig. 4-19 for an illustration of the relationship between output voltage and degree of wear.

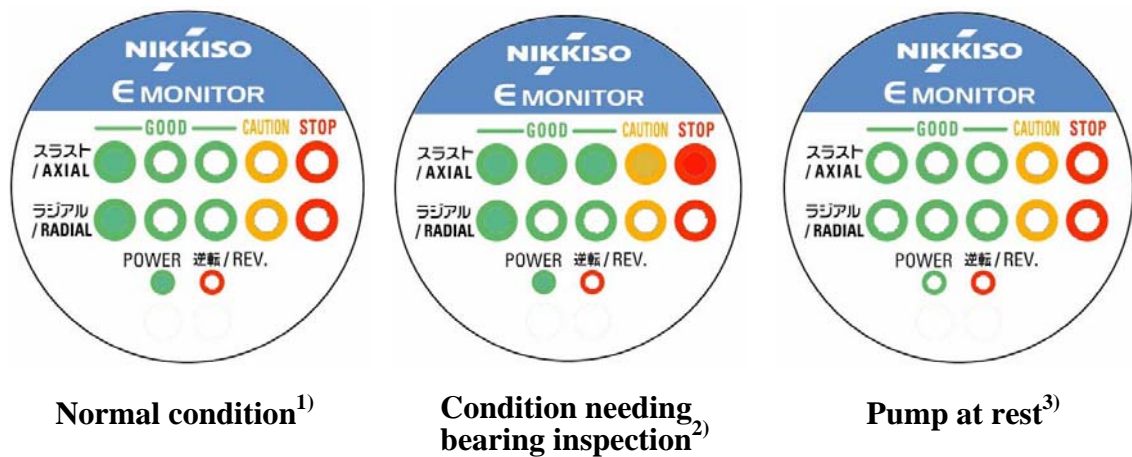

Fig. 4-16 Display Section of E-MONITOR

[Notes]

- 1) We recommend recording the initial operating values to enable trend control. The control setting is such that the number of lighting LEDs is 1 for axial and 1 for radial in the initial operation stage. (If the ambient temperature is low, there is a case that it takes few minutes until E-MONITOR output is stable.)
- 2) If the E-MONITOR display section lights in red in either of axial and radial, the bearing needs to be replaced. (If one red is lit, the output voltage is approximately 4.5V. Refer to Fig. 4-19.)
- 3) The POWER indicator lamp is not lit when the pump is at rest.

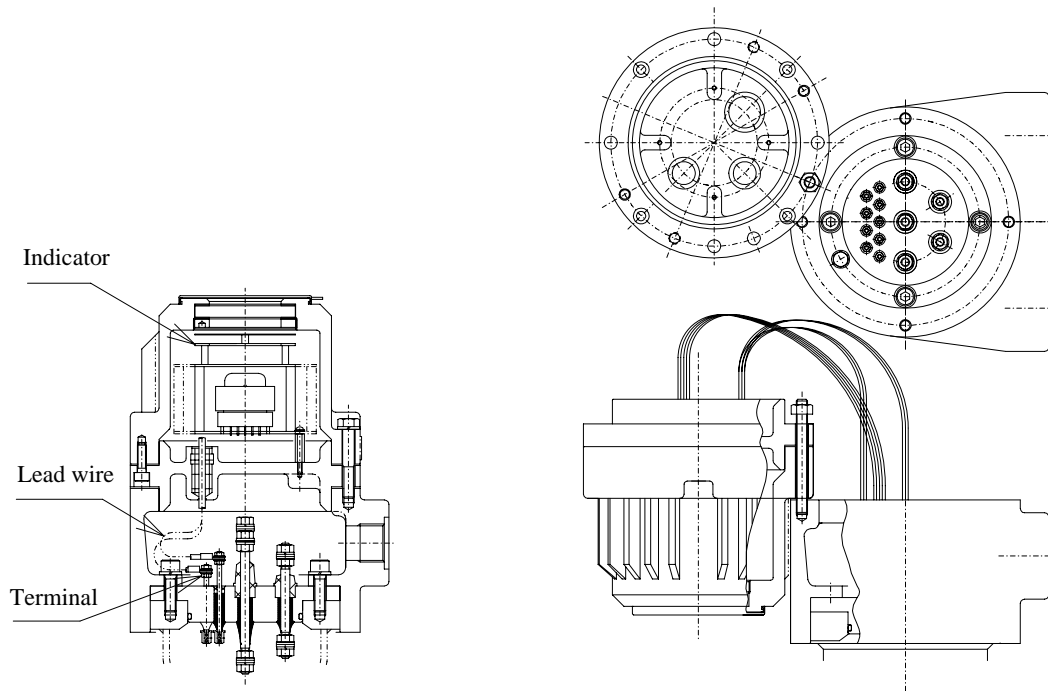

Fig.4-17 Structure of Terminal

(2) Remote type (See Instruction manual of Remote Type E-Monitor No.2246)

The 'remote type' E-MONITOR is usually installed at a location (e.g., central control room) remote from the pump in which a 'field type' E-MONITOR is mounted. The 'remote' monitor's input terminals receive RS422 from the 'field' E-MONITOR to illuminate LEDs – thus facilitating remote monitoring of the bearing.

To perform remote type, connect the No.1, 2, and 6 terminals (refer to Fig. 4-18) to the indicator and observe the following instructions:

- If using an indicator not manufactured by Nikkiso, input impedance of connected indicator needs more than $1M\Omega$ (voltage), less than 10Ω (current) and RS422-standard-based (RS422).
- We recommend using a shield wire for the cable connecting the terminal section of the terminal assembly to the indicator.

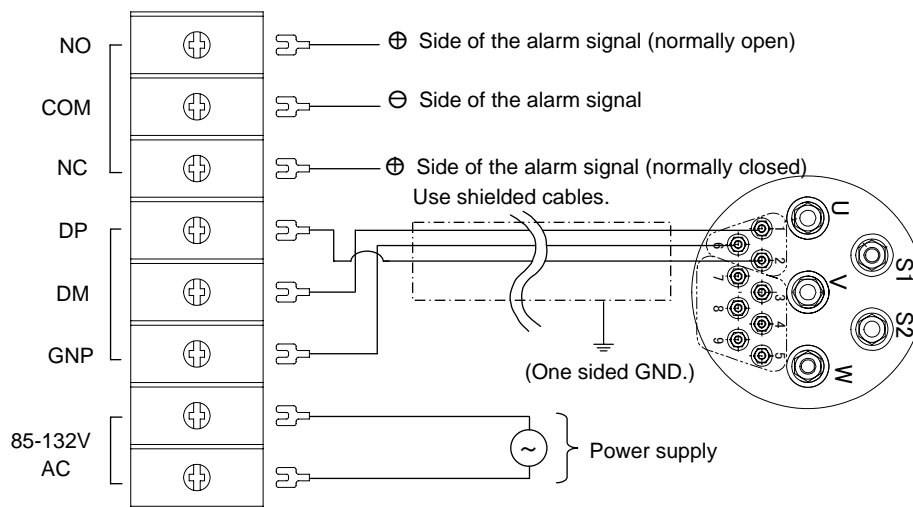

Fig. 4-18 Connection Details of Remote Type E-MONITOR

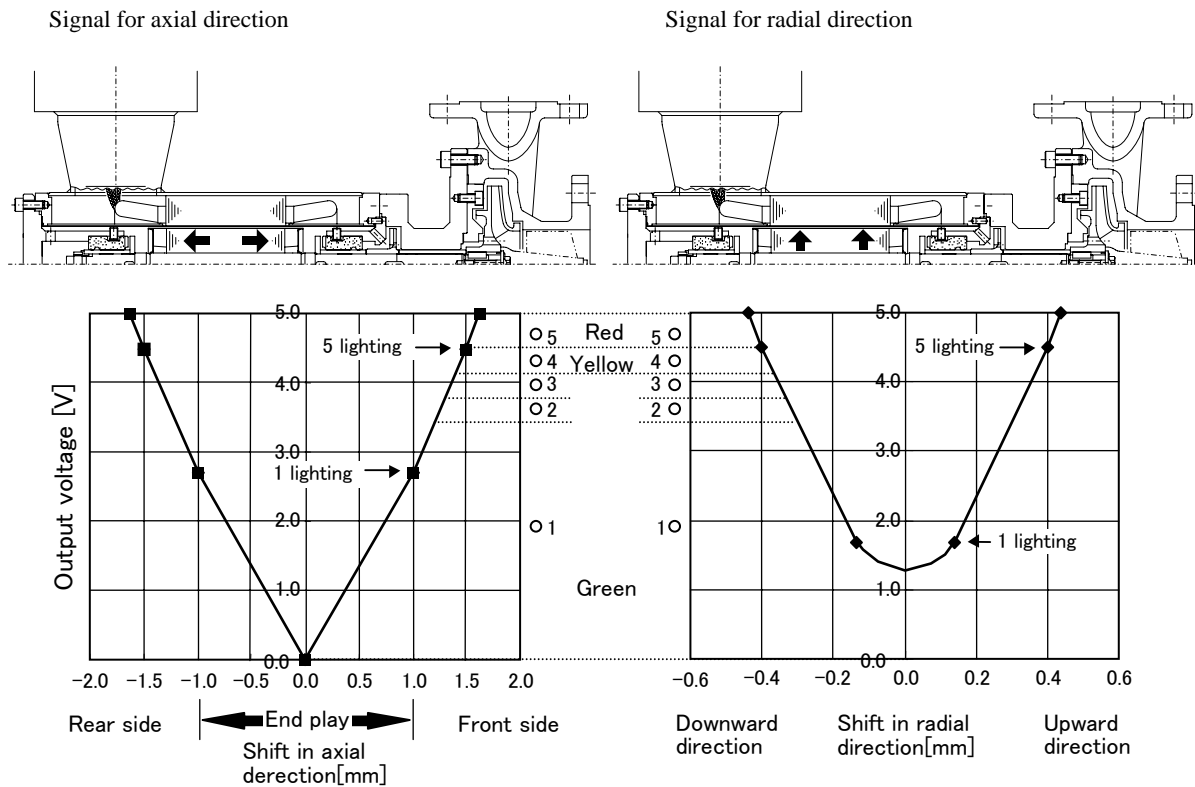

Fig. 4-19 Relationship Between the Output Voltage and Wear

CAUTION

- (1) When opening the terminal box to connect the power cable, take care to avoid damaging the terminal section of the terminal assembly and the lead wires and power supply cables (or power cables) of the E-MONITOR display section. Before beginning, invert the E-MONITOR display section with the temporary fixing pin, then put aside temporarily.
- (2) Avoid subjecting the E-MONITOR display section to impact or shock.
- (3) In addition to bearing wear, the E-MONITOR display section is subject to some extent to changes in pump discharge flow rates and power supply voltage. Always confirm that the pump discharge flow rate and power supply voltage are at rated levels before checking bearings, even when the indicator shows STOP.
- (4) "REV" lamp might be lighted at jogging.

4.5 Method of Reassembly

Reassembly is the reverse of disassembly. Pay attention to the following points. For bolt tightening torques in reassembly, refer to Table 4-4.

Table 4-4 Table of Bolt Tightening Torques Unit:N·m (kgf-m)

BOLT DESIGNATION	MATERIAL	
	SCM 435	SUS 316
M6	15 (1.5)	12 (1.2)
M8	35 (3.5)	28 (2.8)
M10	69 (7.0)	51 (5.2)
M12	98 (10)	69 (7.0)
M16	147 (15)	94 (9.6)
M20	294 (30)	138 (14)
M24	686 (70)	392 (40)
M30	882 (90)	539 (55)

(1) When replacing the bearing (B012)

(a) Motor frame No. H1, H2

Insert the sheet (S26) into the cut-out provided on the outer periphery of bearing before mounting on the housing. Then, insert the bearing into the housing and tighten the setscrew (231) until it strikes the sheet and the bearing can move slightly to left and right. (Refer to Fig.4-20(a).) Tightening the setscrew (231) too tightly causes the bearing to be worn out earlier.

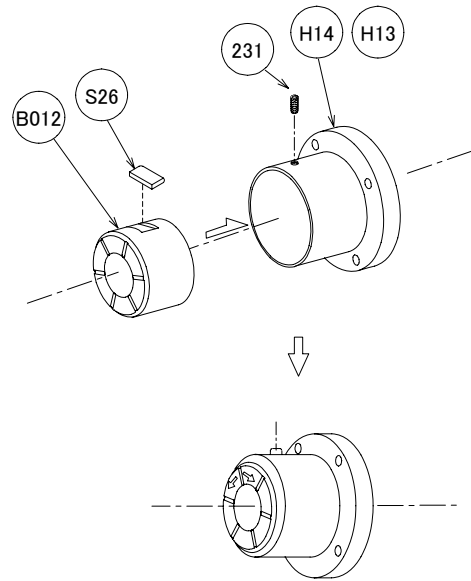

Fig.4-20(a) How to Fix Bearing (Motor Frame No. H1, H2)

(b) Motor frame No. J1-J4, K1-K4

Insert the bearing into the housing, and after setting the bent portion of the washer (W07) to one end of the housing, tighten the setscrew (231) on them. Then, bend the seat surface of the washer on one face of the hexagonal bolt head of the setscrew firmly. (Refer to Fig.4-20(b).)

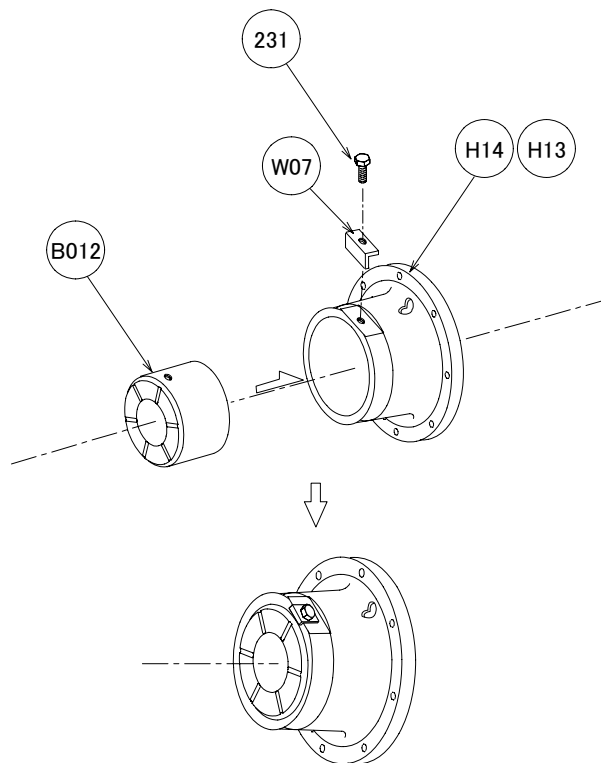

Fig.4-20(b) How to Fix Bearing (Motor Frame No. J1~J4, K1~K4)

- (2) When replacing the thrust washer (W05), do not forget mounting the key (K012).

CAUTION

The plated surface should face outside.
 If the plated glossy surface is not in the sense shown in Fig.4-21, the bearing will wear soon. Then, mount the shaft sleeve (S30). (In the case of hard chrome plating).

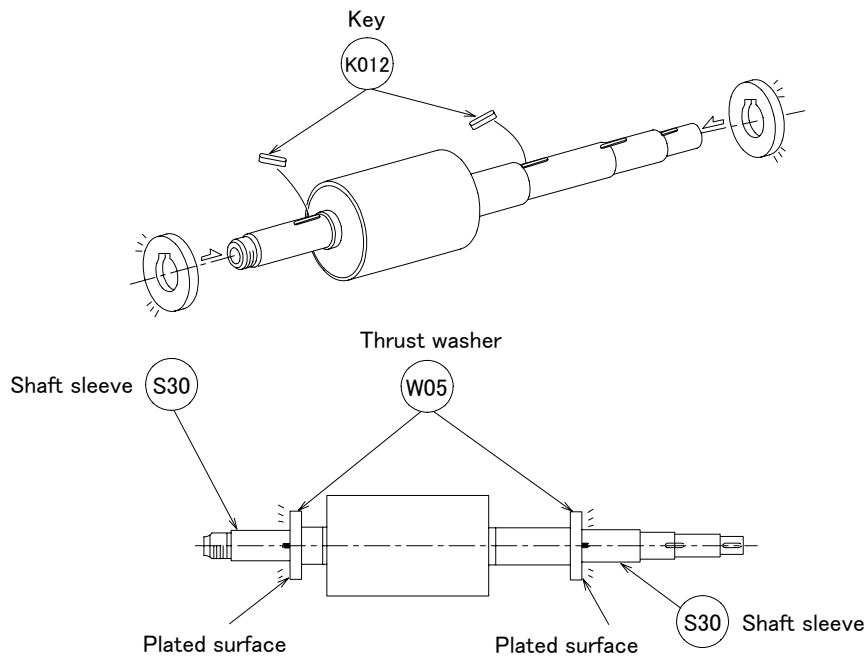

Fig.4-21 Sense of Thrust Washer

- (3) Before mounting the end nut (N07) in the shaft, insert the tongued washer (W072), and after tightening the end nut, bend the tongued washer to prevent the end nut from loosening. (Refer to Fig.4-22.)

The tongued washer should be set not to be eccentric. Be sure to replace the tongued washer at each time of disassembly.

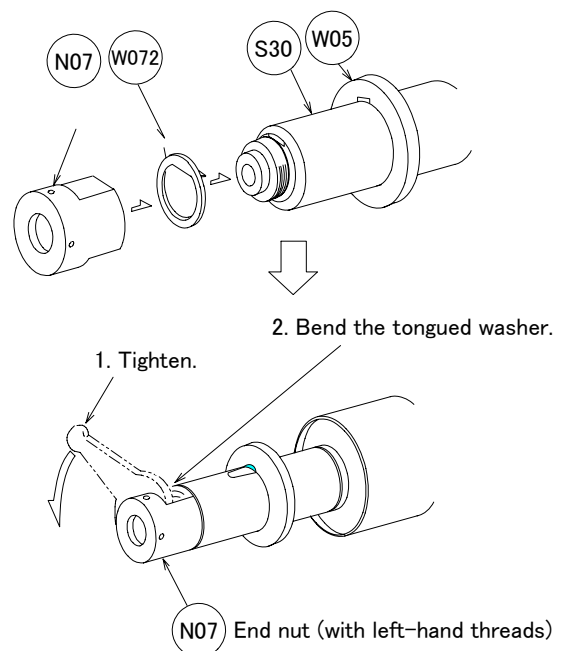

Fig.4-22 Mounting of Tongued Washer

- (4) When mounting the rear cover (C30), RB housing (H14), FB housing (H13), adapter plate (P22) and liner disk (D05), take care not to forget mounting the gasket (313) and (312) and tighten bolts uniformly. (Refer to Fig.4-23.)

Centers are secured by socket and spigot joints and the perpendicularity is measured on the flange surface, therefore, there is no need of conducting centering.

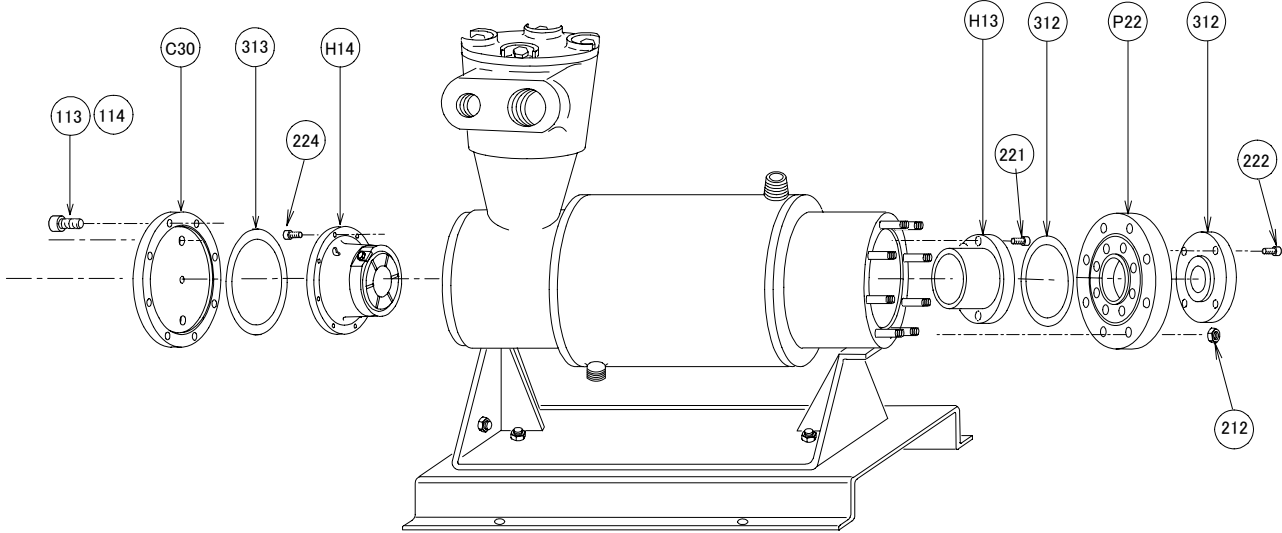

Fig.4-23 Method of Mounting (Motor Frame No. H1, H2)

4 Check and Maintenance

- (5) When mounting the FB housing (H13) and liner disk (D05), tighten bolts (221) or (222) uniformly and firmly. Loose tightening may cause a fault. The liner disk should be positioned so that the marking “UP” be upward and circulation holes are arranged at top and bottom, because circulation holes serve for both air venting and draining. At this time, the bearing setscrew (231) in the FB housing should be positioned upward. (Refer to Fig.4-24.)

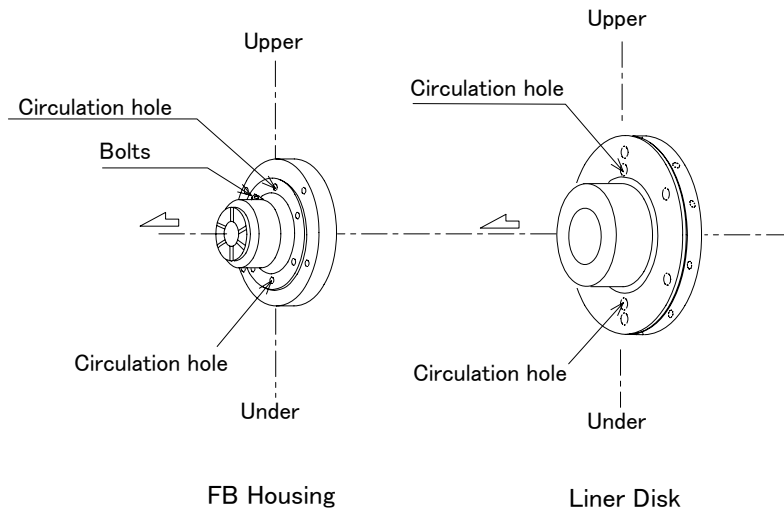

Fig.4-24 Sense of FB Housing and Liner Disk

- (6) When mounting the adapter plate (P22), take care to insure that the marking “UP” be upward and holes for mounting bolts for the adapter plate casing (C20) be distributed symmetrically.
- (7) When mounting the bearing monitor, insert the end of the sensor portion of the bearing monitor into the hole drilled eccentrically on the end nut (N07) while holding the bearing monitor in an inclined position, and then tighten the nut (N02) slowly. This completes mounting.

- (8) When mounting the impeller (J12), confirm that there is no play of the key (K011).

CAUTION

- (1) Tighten the impeller bolt (B20) firmly with the torque shown in Table 4-5.
Tightening by holding the impeller merely using one hand is insufficient. Use a lever or the like as inserted in the impeller. (Refer to Fig.4-25.)
- (2) As these impeller bolts, be sure to use exclusive-use bolts having through-holes. Never use ordinary bolts. If any bolts having no through-hole is used, The circulation flow to the rotor chamber may be insufficient, causing the bearing or motor to be damaged. Screw threads are of special specifications.

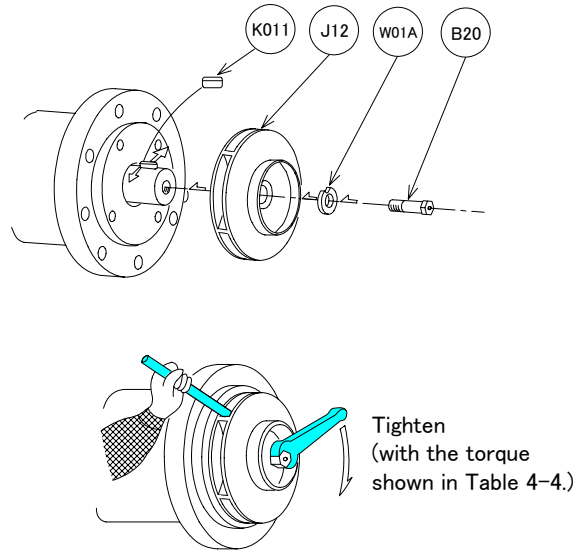

Fig.4-25 Fixing of Impeller

After tightening the impeller bolt, bend the washer of the washer assembly (W01A) correctly along one face of the hexagon bolt head. (Refer to Fig.4-26.) After complete mounting of the impeller, but before mounting the casing, turn the impeller by hand to see that it turns lightly. If it is resistive, disassemble and check to see that the FB housing (H13) and the RB housing (H14) are correctly mounted and that the shaft (S03) is not bent.

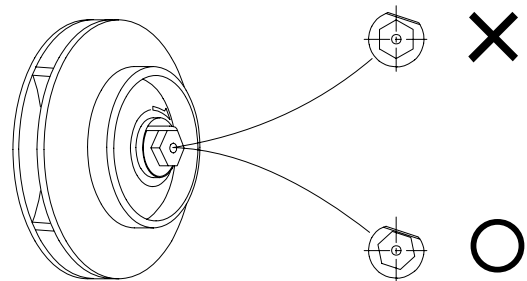

Fig.4-26 Bending of Washer

Table 4-5 Impeller Bolt Tightening Torques

MOTOR FRAME NO.	BOLT SIZE	TIGHTENING TORQUE N·m(kgf·m)
H1, H2	M16	94(9.6)
J1, J2, J3, J4	M20	138(14)
K1, K2, K3, K4	M30	539(55)

4 Check and Maintenance

- (9) Casing mounting bolts (111) should be tightened uniformly in sequence in symmetrical positions. They should not be one-sidedly tightened. (Refer to Fig.4-27.)

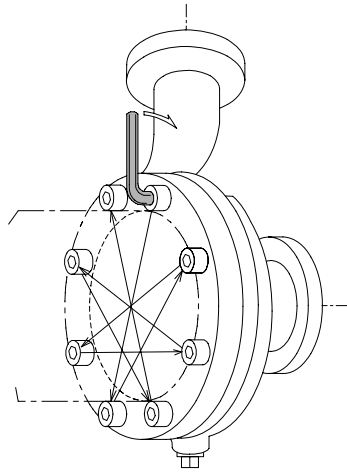

Fig.4-27 Bolt Tightening Sequence

- (10) When mounting the jacket (J01), follow the instructions given on the drawing of outline dimensions. (Refer to Fig.4-28.)

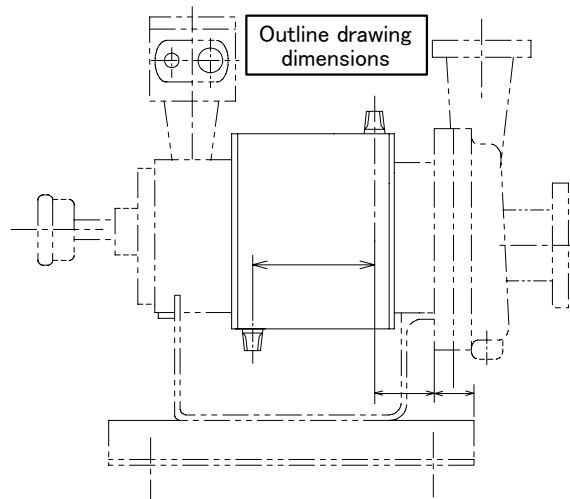

Fig.4-28 Confirmation of Jacket Position

5 Troubleshooting

5.1 Troubleshooting

Table 5-1 summarizes pump trouble symptoms, probable causes and remedies.

In general, plural causes interact with each other and it is not simple to determine the appropriate cause(s). Therefore, this table should be used as a guide. If it is impossible to judge, please contact the manufacturer.

Table 5-1 Troubleshooting (Common for All Types)

SYMPTOM	PROBABLE CAUSES	REMEDIES	
1. Bearing wears early. (Bearing life is short.)	1.1 Handled liquid contains foreign substances (pipe rust, sludge, etc.).	a. Install a strainer (60-80 mesh) in the pump suction piping.	
	1.2 Lubrication is not good.	(1) Air venting of the pump and motor chamber is insufficient.	a. Conduct air venting completely in accordance with this manual.
		(2) Cavitation of the main impeller	a. Check NPSHA. (Measure suction pressure and temperature.)
			b. If the impeller has received secular changes, replace with a new one.
		(3) Cavitation of the auxiliary impeller (in the case of high temperature type or slurry handling type)	a. Prevent cavitation of the main impeller. (Check NPSHA.)
			b. Check the back flushing liquid pressure.
		(4) Gas is entrained (2-phase flow liquid, etc.).	a. Check pump suction conditions (NPSHA) and prevent gas ingress.
(5) Circulation flow lowers.	a. Clean the inside of the circulation piping.		
	b. Clean the internal filter. (Usually, this filter is not mounted.)		
	c. If the auxiliary impeller performance is degraded (due to corrosion and erosion), replace with a new one.		
(6) Liquid properties are not proper (low viscosity, low specific heat, etc.)	a. Change the bearing and/or shaft sleeve material.		
	b. Change the pump construction. (Change to the reverse circulation type, slurry handling type or the like is conceivable. Please contact the manufacturer.)		

SYMPTOM	PROBABLE CAUSES		REMEDIES
1. Bearing wears early. (Bearing life is short.)	1.3 Face pressure is too large.	(1) Radial load is too large.	a. Check to see that the operating flow is within the proper range. (Is it below the minimum flow or too large?)
		b. Check rotating parts (impeller, rotor, etc.) for dynamic balance and if necessary, correct.	
		(2) Thrust load is too large.	a. Adjust the back flushing pressure to the value shown on the specification (in the case of slurry handling type).
			b. Adjust the reverse flow and pressure to the values shown on the specification (in the case of reverse circulation type).
	1.4 Liquid properties	(1) Bearing and/or shaft sleeve has sticking foreign substances (polymers, deposits, etc.).	a. Improve the liquid properties (temperature condition, etc.).
		b. Change the pump construction. In this case, contact the manufacturer.	
(2) Bearing, shaft sleeve, thrust washer, etc. have been corroded.	a. Change the materials to be used.		
2. Motor current increases.	2.1 Increase of liquid load	(1) Change of liquid properties (large specific gravity, high viscosity)	a. Check liquid properties.
			b. Size up the motor.
	(2) Increase of pump flow (process flow, pump internal circulation flow)	a. Check the process operating conditions.	
		b. Disassemble the pump and check internal parts.	

SYMPTOM	PROBABLE CAUSES		REMEDIES	
2. Motor current increases.	(3) Increase of pump internal fluid resistance (roughening of internal surfaces due to corrosion, erosion, and/or foreign substance ingress).		a. Disassemble the pump and check the casing and impeller. (If the surfaces have been roughened, finish with sand paper or by machining. If badly damaged, replace with new ones.)	
	2.2 Increase of Mechanical loss	2.2.1 Motor side	(1) Abnormal symptoms on the bearing sliding surface (wear, foreign substance sticking, corrosion)	a. Replace the bearing, shaft sleeve, thrust washer, etc.
			(2) Loosening of bearing retaining portion	b. Remove the cause of bearing wear. a. Retighten bolts.
			(3) Contact between rotor and stator	a. Check the rotor and stator can surfaces. (Check for abnormal symptoms such as swell, etc.) a. Remove the cause of bearing wear. Refer to “4.3 Bearing Check”.
		2.2.2 Pump side	(1) Contact between impeller and casing	a. Check the shaft for bending. (If it is bent, correct or replace with a new one.)
			(2) Ingress of foreign substances	a. Remove the pump casing and check for presence of foreign substances inside the pump.
		2.3 Abnormal symptoms in the motor portion	2.3.1 Stator	(1) Decrease of insulation resistance (due to moisture absorption).
	(2) Unbalance of resistance between windings			b. Dry by blowing N ₂ gas into the stator or by other means.
	(3) Lack of phase (short-circuit)			c. If insulation resistance and winding resistance cannot be corrected, replace the stator.
	(4) Metal attachment to the stator can surfaces.			a. Disassemble and check the motor portion and if attachment is found, clean to remove it.

5 Troubleshooting

SYMPTOM	PROBABLE CAUSES		REMEDIES	
2. Motor current increases.	2.3.2 Rotor	(1) Metal attachment to the rotor can surfaces.	a. Disassemble and check the motor portion and if attachment is found, clean to remove it.	
		(2) Break of rotor bars	a. Replace the rotor with a new one.	
	2.3 Abnormal symptoms in the motor portion	(1) Loosening of terminal bolt connections		a Check the tightened condition of connections in the terminal box, and if loosened, retighten.
	2.4 Electric wires	(1) Voltage variation		a. Check electric wires.
		(2) Frequency variation		
		(3) Voltage dispersion between phases		
	2.5 Instruments	(1) Ammeter defective		a. Check ammeter. (Replace with other one.)

SYMPTOM	PROBABLE CAUSES	REMEDIES
3. Rotor locks. (Rotor does not rotate.)	3.1 Locking of the casing and impeller.	a. Disassemble the pump and remove foreign substances.
		b. Install a suction strainer.
		a. Replace the bearing (shaft sleeve). b. Remove the cause of bearing wear. Refer to "4.3 Bearing check".
		c. Check the bearing monitor periodically.
	a. Correct bending (or replace with a new one).	
	a. Measure the cocentricity and if abnormal, replace the parts.	
	3.2 Locking of stator liner and rotor sleeve	a. Install a suction strainer.
		b. Check liquid properties.
		a. Check the handled liquid temperature.
		b. Check the jacket cooling water flow.
		a. Conduct the liquid penetrant inspection of welds.
		b. In the case of corrosion, change the can material.
	3.3 Locking of bearing and shaft sleeve	a. Remove the cause of bearing wear. Refer to "4.3 Bearing Check".
		b. Install a suction strainer. Check liquid properties.
		a. Change material and dimensions of bearing (shaft sleeve).

5 Troubleshooting

SYMPTOM	PROBABLE CAUSES	REMEDIES
3. Rotor locks. (Rotor does not rotate.)	3.4 Others (1) Burn-out of motor	a. Replace the stator.
		b. Replace the rotor
		c. Check the motor starting characteristics and load characteristics.
		d. Check the power supply.
4. Thermostat operates frequently.	(1) Motor overloaded	a. Check the operating flow. b. Check the liquid specific gravity and viscosity.
	(2) Motor cooling is insufficient. (Motor portion is overheated.)	a. Check the jacket cooling water flow. b. Check the handled liquid temperature. c. Clean the circulation pipe inside. d. Clean the jacket inside.
	(3) Thermostat set value is deviated (under the high temperature conditions).	a. Switch to another thermostat (if two units are mounted).
	(4) Thermostat itself is defective.	b. Replace the stator.
5. Vibration is large (increases).	(1) Bearing wear	a. Remove the cause of bearing wear. Refer to “4.3 Bearing check”.
	(2) Contact between casing and impeller.	a. Check the part dimensions. b. Correct the shaft bending.
	(3) Loosening of base mounting bolts.	a. Retighten bolts.
	(4) Occurrence of cavitation	a. Check NPSHA.
	(5) Operating flow is not proper (too large, too small).	a. Check the operating conditions.
	(6) Direction of rotation is not proper (reverse rotation).	a. Change the connections for normal rotation.
	(7) Resonance with piping systems	a. Reinforce the piping support.
	(8) Rotating system (rotor, impeller) dynamic balance is not proper (lost).	a. Check dynamic balance and if it is lost, correct.

SYMPTOM	PROBABLE CAUSES	REMEDIES
6. Large sound (abnormal sound)	(1) Air venting is insufficient.	a. Conduct air venting completely.
	(2) Direction of rotation is not correct (reverse rotation)	a. Change the connections for normal direction.
	(3) Operating flow is not proper (too large, too small).	a. Check the operating conditions.
	(4) Occurrence of cavitation	a. Check NPSHA.
	(5) Ingress of foreign substances (anything hard)	a. Install a strainer.
	(6) Water cutting sound of casing (especially in the case of open impeller)	a. This is a fluid sound and requires no remedy.
		b. Check the operating flow (too large flow).
	(7) Fluid sound in the circulation tube	a. This is a fluid sound and requires no remedy.
	(8) Contact between casing and impeller	a. If the bearing wears out, replace the bearing (shaft sleeve).
b. If the shaft is bent, correct the bending.		
c. Contacting parts of the casing and impeller should be finished to correct. (If the contact damage is deep, replace with new ones.)		
(9) Loosening of internal bolts	a. Disassemble the pump and check the bolts for loosening. (If loosened, retighten.)	
7. Pre-deter-mined flow (dis-charge pres-sure) is not obtained.	(1) Motor is in reverse rotation.	a. Check the direction of rotation, and if necessary, change connections.
	(2) Occurrence of cavitation (insufficient NPSHA, air suction)	a. Check NPSHA. (Measurement of suction pressure, cleaning of strainer, check of piping loss, etc.)
		b. Retighten suction piping connections (flange, piping parts).
	(3) Different liquid properties	a. Check the liquid specific gravity, viscosity, etc. against the specification.
	(4) Incorrect measurements	a. Check measuring instruments (flow meter, pressure gauge).
b. Check the flow to bypass pipings.		

6 Periodical Check

6.1 Implement of Periodical Check

The Non-Seal pump requires periodical check once a year. Merely because the pump operation is in good order, do not operate the pump continuously for 2 or 3 years without check.

6.2 Items to be checked in Periodical Check

- (1) Bearing wear
- (2) Shaft sleeve, thrust washer, etc. wear
- (3) Loosening of mounting bolts in the various portions
- (4) Clogging of jacket
- (5) Wear due to corrosion, etc. (of can, wear ring, etc.)
- (6) Clogging of through-holes in the pump (especially, those of shaft and impeller bolts)
- (7) Motor insulation resistance and winding resistance
- (8) Checking of the inside of terminal box (connection side)

If there is a standby pump installed in parallel, switch the operation between the normal and the standby pump at predetermined intervals such as 3 or 6 months.

The pump taken out of operation should be checked and serviced as soon as possible in accordance with 6.2 above, so that it may be ready for restarting. The standby pump to be stored also should be checked and serviced before placing in storage.

7 Spare Parts

7.1 Spare Parts

As shown in Table 7-1, spare parts can be used in common for some Frame Nos. of drive motors in the SGM large capacity series.

Except for special cases, it will be convenient in general to have spare parts on hand by the quantities per unit shown in the table. If plural pumps are used, it will be convenient to manage their spare parts collectively.

Table 7-1 Table of Spare Parts

NAME OF PART	NO.	Q'TY PER UNIT	MOTOR FRAME NO. COMMON RANGE			DEMANDS
Bearing	B012	1 set of 2 pieces	$\left\{ \begin{array}{l} H1 \\ H2 \end{array} \right.$	$\left\{ \begin{array}{l} J1 \\ J2 \\ J3 \\ J4 \end{array} \right.$	$\left\{ \begin{array}{l} K1 \\ K2 \\ K3 \\ K4 \end{array} \right.$	
Shaft sleeve	S30	1 set of 2 pieces				
Thrust washer	W05	1 set of 2 sheets				
Washer assembly	W01A	1 set of 1 sheet				
Tongued washer	W072					
Jacket portion gasket	331	1 set of 2 pieces (Refer to Table7-2.)				
Motor portion gasket	312 313	1 set of 1 sheet (Refer to Table7-3.)				
Pump portion gasket	311	1 set of 1 sheet	Depending on pump No. (Refer to Table 7-4.)			
Bearing monitor portion gasket	314	1 piece	Common for all Motor frame Nos.			

Table 7-2 Dimensions of Jacket Portion Gasket (331) Unit:mm

MOTOR FRAME NO.	INTERNAL DIAMETER	THICKNESS
H1, H2	260	φ 5.7
J1, J2, J3, J4	318	φ 8.4
K1, K2, K3, K4	380.4	φ 8.4

Table 7-3 Internal Diameter Dimensions of Motor Portion Gasket Unit:mm

MOTOR FRAME NO.	PUMP SIDE [312]	RB HOUSING SIDE [313]	THICKNESS
H1, H2	243.8	188.8	φ 3.1
J1, J2, J3, J4	292.8	240.8	
K1, K2, K3, K4	347.8	285.8	

Table 7-4 Dimensions of Pump Portion Gasket (311) Unit:mm

PUMP NO.	INTERNAL DIAMETER	EXTERNAL DIAMETER	THICKNESS
46A	271	251	1.5
46B	325	305	
47B	331	311	
47C	385	361	
47D, 48C	455	431	
48D	551	521	

8 Services

8.1 Check

Before asking services, conduct pump check in accordance with Table 8-1.

8.2 In the Event of Damage

In the event that the winding, stator liner or rotary sleeve is damaged, contact the manufacturer. It is difficult to repair it on the site.

NOTE

The SGM large capacity series adopts the building block system. Subassemblies of the stator assembly (S36), rotor assembly (R16), jacket (J01), etc. may be replaced, in some cases, on subassembly basis on the site. (Refer to Fig.8-1.)

However, in such cases, careful confirmation of specifications, materials, etc. is necessary. Please contact the manufacturer.

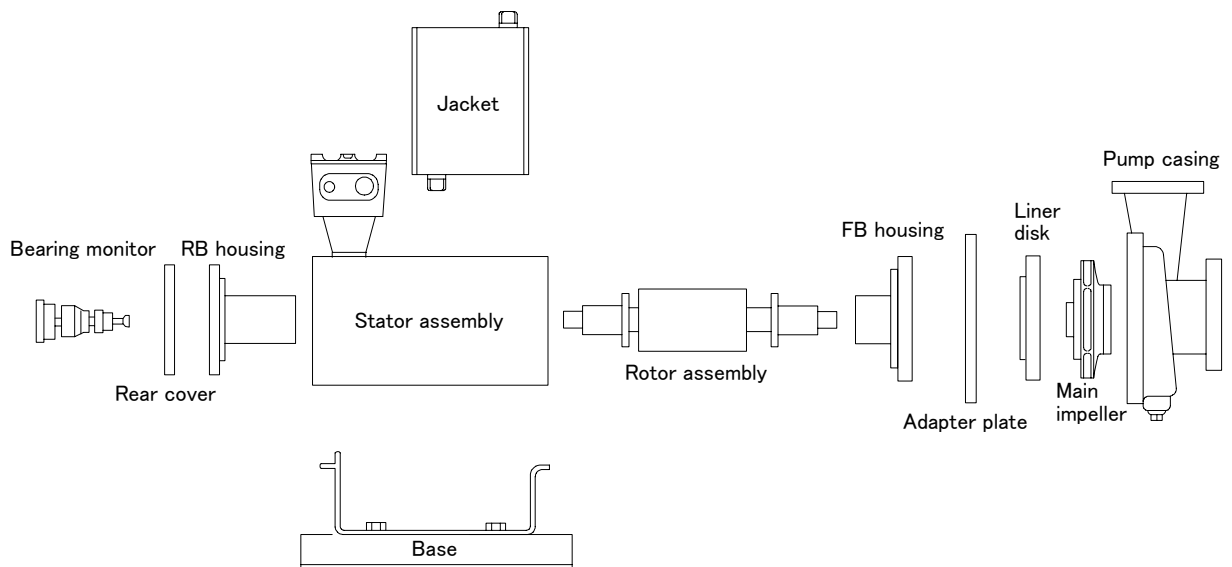

Fig.8-1 Replacement by Subassemblies

8.3 When Returning

⚠ WARNING

When returning the pump to the manufacturer, be sure to drain out the liquid beforehand for safety. If any hazardous liquid remains, it may be impossible in some cases to repair it at the manufacturer.

When returning the pump to the manufacturer, confirm the pump model and Serial No. without fail.

If retesting after repair is required, please return the entire pump.

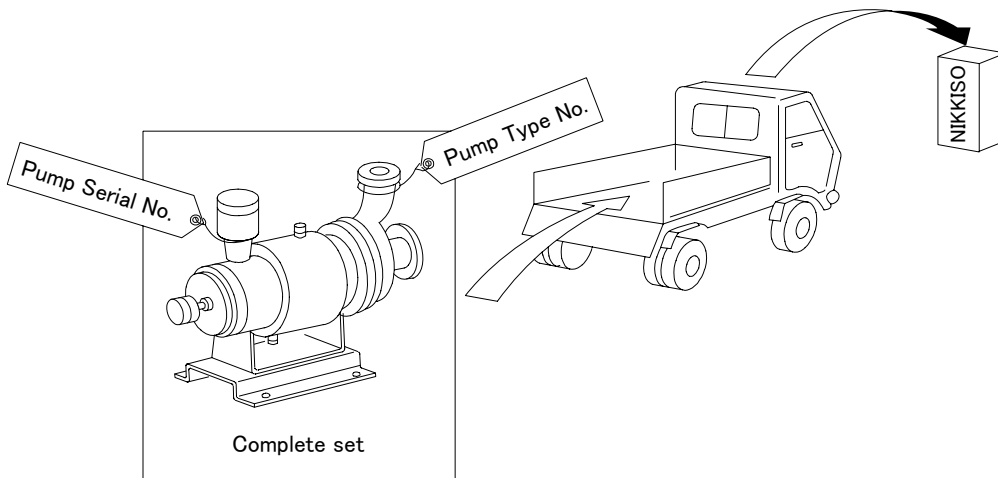

Fig.8-2 Markings for Sending to the Manufacturer

Before returning the pump, wash the pump with water sufficiently. When ordering any spare part, state the pump model, Serial No., Part name, material and quantity clearly.

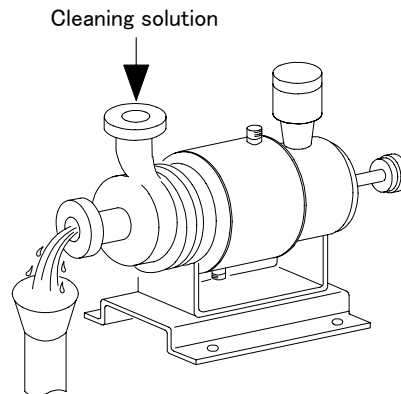

Fig.8-3 Cleaning of Liquid End

Table 8-1 Troubleshooting Chart (○: Applied)

SYMPTOM	PROBABLE CAUSE
Failing to start	<input type="checkbox"/> Power supply not adequate <input type="checkbox"/> Thermostat defective <input type="checkbox"/> Insulation deteriorated <input type="checkbox"/> Rotor locking <input type="checkbox"/> Can corroded <input type="checkbox"/> Impeller corroded <input type="checkbox"/> Shaft sleeve corroded or worn out <input type="checkbox"/> Bearing worn out <input type="checkbox"/> Contact between impeller and casing <input type="checkbox"/> Thrust balance poor <input type="checkbox"/> Shaft bent <input type="checkbox"/> Piping system vibration or surging <input type="checkbox"/> Foreign substance ingress <input type="checkbox"/> Direction of rotation incorrect <input type="checkbox"/> Impeller clogged <input type="checkbox"/> Discharge resistance (head) too large <input type="checkbox"/> Liquid viscosity larger than specified <input type="checkbox"/> Liquid specific gravity larger than specified <input type="checkbox"/> Flow too large <input type="checkbox"/> Circulation system clogged <input type="checkbox"/> Shutoff operation or flow too small <input type="checkbox"/> Jacket, heat exchanger cooling water insufficient <input type="checkbox"/> Priming poor <input type="checkbox"/> Air venting poor
No liquid coming out	<input type="checkbox"/> NPSH poor (cavitation) <input type="checkbox"/> Suction side air ingress <input type="checkbox"/> Suction side air or vapor accumulated <input type="checkbox"/> Suction pipe clogged <input type="checkbox"/> Service conditions changed (pump converted for different use)
Flow not as specified	<input type="checkbox"/> Discharge pressure not as specified <input type="checkbox"/> Flow insufficient after startup <input type="checkbox"/> Motor current over <input type="checkbox"/> Overheated <input type="checkbox"/> Vibration <input type="checkbox"/> Noise <input type="checkbox"/> Bearing sticking <input type="checkbox"/> Thermostat operated <input type="checkbox"/> Bearing monitor operated
Discharge pressure not as specified	<input type="checkbox"/> No liquid coming out with increasing liquid temperature <input type="checkbox"/> No liquid coming out and current increased with decreasing liquid temperature
Flow insufficient after startup	<input type="checkbox"/> Check connections, motor windings, fuse, etc. <input type="checkbox"/> Check, and if defective, replace stator assembly. <input type="checkbox"/> Check insulation resistance and dry motor. <input type="checkbox"/> Disassemble and check. Galling due to bearing sticking or contact of rotor assembly. <input type="checkbox"/> Repair or replace stator assembly or rotor assembly. <input type="checkbox"/> Change can material. <input type="checkbox"/> Repair or replace. Change material. <input type="checkbox"/> Replace. If any problem, change material. <input type="checkbox"/> Replace. <input type="checkbox"/> Readjust. Replace bearing. <input type="checkbox"/> Readjust. <input type="checkbox"/> Repair. <input type="checkbox"/> Check piping system and remove cause. Piping to be free from surging. <input type="checkbox"/> Check piping system. Check strainer. <input type="checkbox"/> Reconfirm direction of rotation, and if necessary, correct connections. <input type="checkbox"/> Clean. Remove cause of clogging. <input type="checkbox"/> Reselect pump. Recheck discharge side piping system. <input type="checkbox"/> Correct to the specification. <input type="checkbox"/> Correct to the specification. <input type="checkbox"/> Throttle discharge side valve to the specified flow. <input type="checkbox"/> Check and clean. Check shaft through-holes as well. <input type="checkbox"/> Take flow sufficiently. If necessary, use bypass operation. <input type="checkbox"/> Run cooling water sufficiently. <input type="checkbox"/> Be sure to use priming. <input type="checkbox"/> Perform venting sufficiently. <input type="checkbox"/> Correct suction conditions to satisfy NPSH requirements sufficiently. <input type="checkbox"/> Prevent ingress. <input type="checkbox"/> Piping to be free from accumulation. <input type="checkbox"/> Check and clean. Sometimes, the cause is in the strainer. <input type="checkbox"/> Before converting, investigate sufficiently.

NIKKISO NON-SEAL PUMP
SGM Large Capacity Series Basic Type
Instruction Manual

No part of this publication may be reproduced or transmitted in any forms or by any means without the prior permission of Nikkiso Co., Ltd.

Manual No. 2200
First Edition April, 2002
Publisher NIKKISO CO., LTD.
FLUID EQUIPMENT FACTORY
ENGINEERING DEPARTMENT
16-2, NOGUCHI-CHO, 2-CHOME,
HIGASHIMURAYAMA
TOKYO 189-8520, JAPAN

NIKKISO CO.,LTD
FLUID TECHNOLOGIES UNIT

Head office 43-2,Ebisu 3-Chome, Shibuya-ku, Tokyo 150-8677, Japan
Telephone +81-3-3443-3726
Fax +81-3-3444-2438
Plant Tokyo, Japan
<http://www.nikkiso.co.jp>

NIKKISO Pumps Europe GmbH _____

Office & Plant Nikkiso Strasse, D-63674
Altenstadt / Hess, Germany
Telephone +49-6047-96490
Fax +49-6047-96499
<http://www.nikkiso-pumps.com>

NIKKISO Pumps America , Inc _____

Office & Plant 600 Kenrick Drive, Suite C-1, Houston,
Texas 77060 U.S.A
Telephone +1-281-310-6747
Fax +1-281-310-6771
<http://www.nikkisoamerica.com>

NIKKISO Pumps Korea Ltd. _____

Office 603, 6F Ilshin Building, 541
Dowha-Dong, Mapo-Gu, Seoul, Korea
Telephone +82-2-719-1446
Fax +82-2-719-1440

NIKKISO Pumps Middle East _____

Office 7F-AI Yasat Tower-Baniyas Street,
P.O.Box 97, Abu Dhabi, UAE
Telephone +971-4-265-9979
Fax +971-4-265-9980

Shanghai Nikkiso Non-Seal Pump Co., Ltd. _____

Office 1795, Huhang Road, Nanqiao Town,
Fenxian District, Shanghai 201400, P.R.C.
Telephone +86-21-6710-3258
Fax +86-21-6710-3250/3251

NIKKISO Shanghai Service Center _____

Office Friendship Building, Shanghai
Petrochemical Complex, Shanghai, P.R.C.
Telephone +86-21-5794-1325
Fax +86-21-5794-1948

NIKKISO Beijing Representative Office _____

Office Room 3201, Jing Guang Center,
Hu Jia Lou, Chao Yang Qu, Beijing, P.R.C.
Telephone +86-10-6597-3011
Fax +86-10-6597-3012

NIKKISO Singapore Representative Office _____

Office 101 Cecil Street, Units #18-11
Tong Eng Building, Singapore 069533
Telephone +65-6221-1235
Fax +65-6221-3244

NIKKISO CRYO, INC. _____

Office & Plant 4661 Eaker Street, North. Las Vegas,
Nevada. 89081, U.S.A
Telephone +1-702-643-4900
Fax +1-702-643-0391

NIKKISO CRYO. EUROPE _____

Office Fountain Court 2, Victoria Square,
Victoria Street, St Albans,
Hertfordshire AL1 3FT, United Kingdom
Telephone +44-0-1727-884-949
Fax +44-0-1727-884-800

NIKKISO accepts no liability for any errors it contains, and reserves the right to alter specifications without notice.