

SGM SERIES SLURRY TYPE HS

INSTALLATION & OPERATION MANUAL

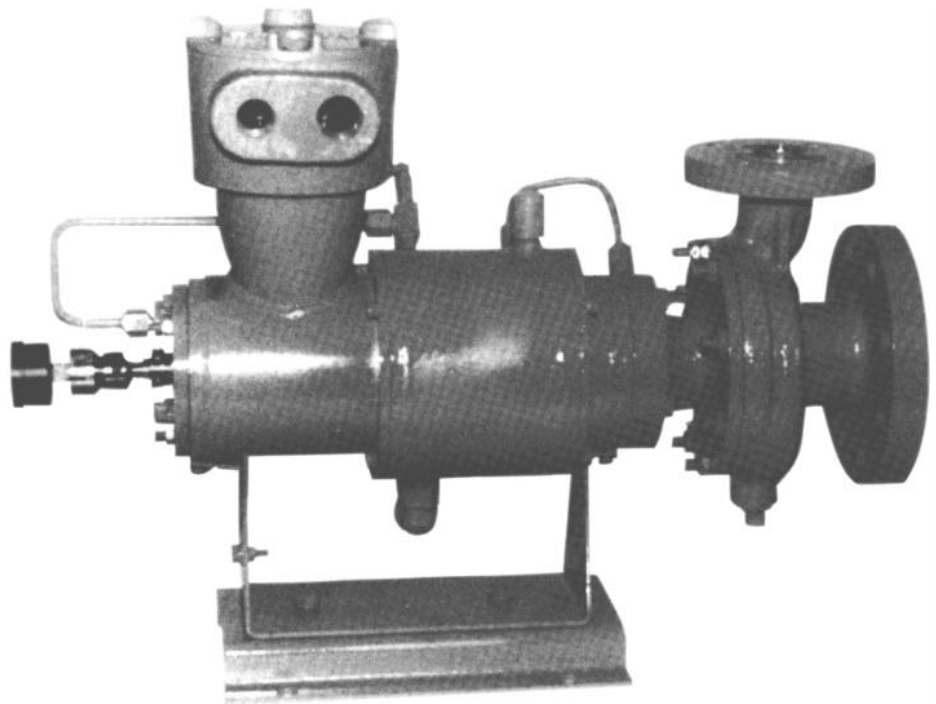

TABLE OF CONTENTS

TITLE	PAGE
Introduction.....	1
Slurry Type HS Construction	1
SECTION I	
Installation	3
Inspection	3
Storage.....	3
Suction & Discharge Piping	3
Auxiliary Piping	4
Electrical Wiring	4
SECTION II	
Operation..	7
Preparatory Procedures	7
Preparation for Starting.....	7
Start-up Procedure	8
Routine Inspection During Operation	8
Minimum Flow Rate.....	8
Emergency Stopping	8
SECTION III	
Maintenance	9
Periodic Check	9
Bearing Monitor.....	9
Bearing Replacement,	10
SECTION IV	
Troubleshooting	13
SECTION V.	
Disassembly & Reassembly Procedure.....	15
Reassemble Pump In Reverse Order.....	19
SECTION VI.	
Recommended Spare Parts.....	21
SECTION VII.	
Cross Sections	22
SECTION VIII,	
Outline Drawings.....	26

WARNING

DO NOT RUN DRY

Motor and bearing heat is removed primarily by internal circulation of the pumped fluid. Overheating and internal failure will occur if the pump is run dry except for 1 to 3 second jogging before initial start-up to check motor rotation, Motor surface temperature will increase if pump is run dry and may exceed safe limits if installed in Class I, Division 2, Group C or D areas Overheating may also cause an unsafe increase in internal pressure when handling higher vapor pressure liquids.

Running the pump dry can be avoided by:

- Providing at least the NPSH required as listed on the specification sheet Suction strainers (60 to 80 mesh) are recommended for start-up but must be monitored to assure that a blocked stainer does not result in insufficient NPSH.
- Using a by-pass or other means to assure that flow is never lower than the minimum value listed on the specification sheet.
- Use of a low level shut down switch or other method to avoid operation at suction tank levels that will not provide the NPSH required.
- Assuring that cooling fluid is provided to the cooling jacket or heat exchanger when required.

CHECK DIRECTION OF ROTATION AND BEARING MONITOR

Allow sufficient space at the rear of the motor for viewing direction of rotation with the bearing monitor removed prior to initial start-up and to check bearing monitor dial periodically.

PROVIDE PROPER PIPE SUPPORTS

The pump base provided is designed to support motor weight during operation and maintenance and will not support piping loads

PROVIDE FOR SAFE DRAINING OF PUMP AND MOTOR PRIOR TO MAINTENANCE

Drain openings are shipped with pipe plugs as standard and flanged openings as an option. Provisions must be made before pump operation for safe draining of pumped fluid prior to maintenance.

USE PUMP ONLY FOR THE SERVICE OUTLINED ON THE SPECIFICATION SHEET

Use for operating conditions other than those shown on the specification sheet requires review by Sundstrand Application Engineering to determine changes which may be required for safe operation.

ALLOW FOR POSSIBILITY OF PUMPED FLUID LEAKAGE

The design eliminates the use of mechanical seals which are the most common leak source in conventional pumps Primary leak containment is provided by the stator liner and secondary containment by the outer motor shell and terminal plate. Although this design greatly improves sealing reliability, errors in assembly or operation, or unforeseen circumstances could result in leakage. Appropriate provisions should be made in the design of the installation and in safety procedures.

THERMOSTATS MUST BE CONNECTED

If thermostats are not connected, overheating and burnout of the motor windings may occur. This can be caused by loss of pump flow (loss of suction, blocked discharge, running backwards, etc), locked rotor, loss of cooling flow to jackets, etc.

MOTOR SURFACE TEMPERATURE DEPENDS ON PUMP FLUID TEMPERATURE AND COOLING FLUID FLOW THROUGH MOTOR.

EACH PHASE OF POWER SUPPLY MUST HAVE OVERLOAD PROTECTION.

CONNECT GROUNDING WIRE TO GROUNDING TERMINAL

Pump is suitable for use in Class I, Division 2, Class C and D areas depending on motor temperature which in turn depends on pump fluid temperature and on cooling liquids when required. These factors must be controlled within limits shown on the specification sheet. Overheating will also occur if the pump is run dry or below minimum flow.

INTRODUCTION

The instructions in this manual are provided to aid in installation, operation, and servicing of the pump. This manual should be read in its entirety before any maintenance or start-up is attempted.

The pump is designed and constructed to meet a specific application. Information that may be required regarding performance, operating limitations optional features, flushing or cooling requirements and other technical details which are not included herein may be found in the specification sheet, performance curve, and drawings for each unit This information is identified by serial number.

SLURRY TYPE HS CONSTRUCTION

The Type HS Canned Motor Pump is a single stage centrifugal unit designed for applications where the liquid being pumped contains solid particles that would damage the shaft bearing if allowed to enter the motor. A clean buffer fluid is constantly recirculated through the motor and an integral heat exchanger to provide cooling and lubrication and to prevent process fluid migration into the motor. The buffer fluid migration into the motor. The buffer fluid is recirculated by an auxiliary impeller and buffer fluid loss is minimized by a close clearance bushing between the motor and pump. The construction eliminates the need for mechanical shaft seals and couplings

The impeller may be either open or closed, depending on the flow and head requirements Some models are fitted with an inducer that lowers the NPSH required

The shaft is protected on both ends by hardened shaft sleeves that fit inside the two journal bearings Thrust washers are installed on either end of the rotor shaft to center the rotor during start-up and shut down and during process up-sets Axial thrust is balanced during normal operation by impeller bleed-back holes and fixed and variable orifices

The rotor and stator windings are sealed in tubular metal liners. Radial clearance between rotor and stator liners is .020 inch, which allows for .016" radial wear on the journal bearings before replacement is required Allowable thrust bearing wear is 0.11 inch. The terminal plate provides secondary leakage protection in the event of liner penetration. Motor and bearing heat is carried away by the pumped fluid. Continuous flow must be assured to avoid equipment damage and possible safety hazards

A Mechanical bearing monitor is installed in the motor end of the pump. This monitor is designed to alert the operator that a problem exists and that a shut down for examination and repair is required. The monitor senses with 98% accuracy excessive radial, as well as axial bearing wear and also detects excessive corrosion.

In all instances, a heat exchanger is required for motor cooling This heat exchanger fits over the stator shell and is sealed by "O" ring gaskets

The motor is protected by thermostat imbedded in the windings The operating point of the thermostat is determined by the insulation class of the motor. Additional information may be found in Section "I. INSTALLATION" on page 4.

SLURRY TYPE PRINCIPLES OF OPERATION

BEARING MONITOR

The standard bearing monitor detects bearing wear so that routine maintenance can be accomplished before serious motor damage occurs. It responds to bearing wear in both the axial and radial directions and is over 98% effective on 60,000 operational units

The interior of the monitor contains either pressurized inert gas or is kept at atmospheric pressures depending on operating conditions. The end of the monitor has a contact tip which is fitted within a cavity in the end nut on the rotor shaft. Clearance between the contact tip and the end nut correspond to the maximum allowable bearing wear.

As bearing wear (either radial or axial) occurs the clearances between the stationary tip and rotating end nut converge. The resulting change in pressure within the interior is displayed on the face of the monitor. A pressure switch for remote alarm/shutdown is optional

In addition, the monitor is useful in detecting corrosion of the stator liner and rotor sleeve since the contact tip is supplied in the same metallurgy but one half the thickness of those components.

EXTERNAL FLUSH PORT
Clean External Flush

SHAFT SLEEVE
Replaced when bearings are changed or like new wear surfaces and clearances

BEARINGS
Oversized for minimum loading Slip fit into housings

TERMINAL PLATE
"O" ring sealing for positive secondary fluid containment

DRY STATOR
Eliminates oil pressure relief valve required for oil filled stators Integrity of secondary leak containment shell is maintained

FLANGES
Self venting centerline discharge

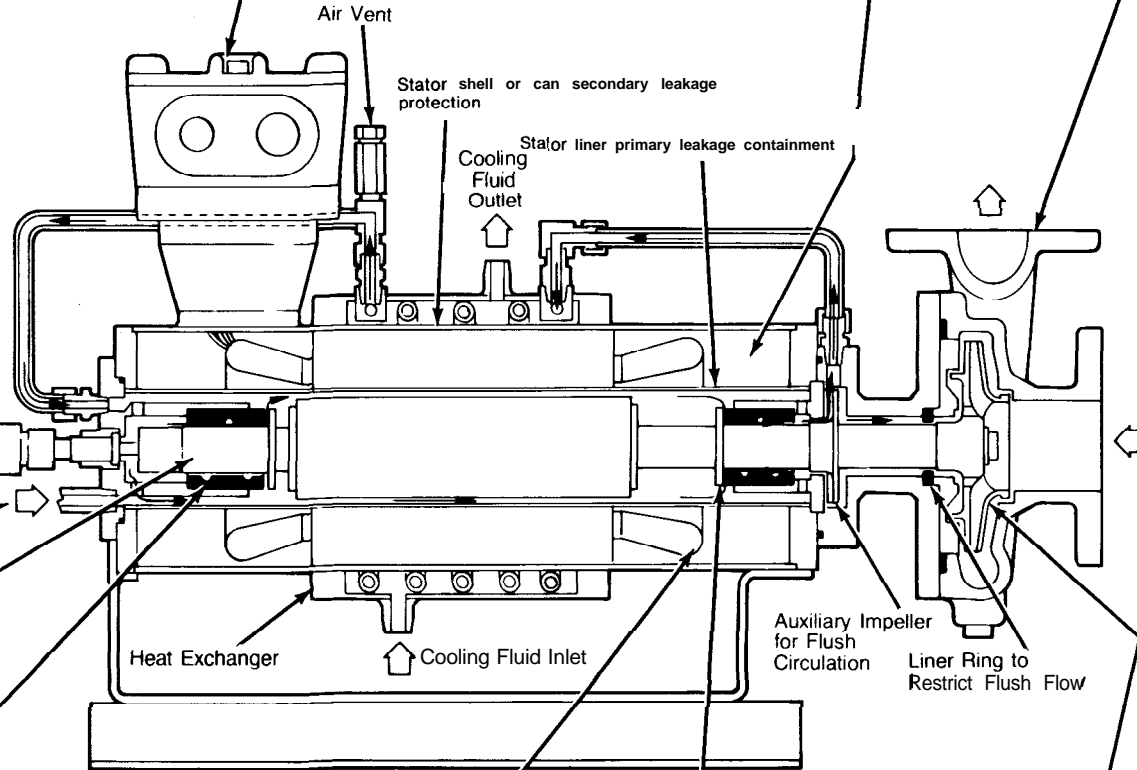

MOTORS
In the Sundyne Canned Motor design, the entire outside of the motor is enclosed in secondary leakage containment shell or can. Primary leakage protection is provided by corrosion resistant liners which are seal welded and 100% leak checked to assure that pumped fluid does not contact the stator windings or rotor core. There is no shaft protrusion to seal and thus no seals to leak

Pumped fluid is circulated inside the stator liner to cool the motor, and lubricate the bearings

Winding temperature is primarily influenced by pumped fluid temperature and secondarily by use of cooling jacket. Fluid temperature is considered in pump application to assure full winding life and safety in Class I, Division 2, Group C & D areas. Operation temperatures greater than shown on specification sheet may damage motor and cause safety hazard

THERMOSTAT
Embedded in the hot spot of windings for protection against overheating

THRUST WASHERS
Absorb thrust loads during upset conditions and provide back-up to hydraulic thrust balancing

IMPELLER
Open and closed configurations. Optional flow inducers available for minimum NPSH requirements

I. INSTALLATION

1. INSPECTION

- A. inspect the shipping container for any evidence of shipping damage. If any visible evidence is seen, it should be noted. It is often helpful to photograph the damage if the extent of damage is uncertain.
- B. Care should be taken when uncrating the pump
- C. Check the bill of lading to determine if any shortages exist. If any freight damage or shortage is determined, it should be noted on both the receipt and freight bill. Make any claim to the transportation company immediately.
- D. Inspect the suction and discharge flanges for damage. If the pump will not be installed immediately, reseal the flanges to protect the pump from contamination.
- E. Verify that the pump identification plate has the correct serial number and agrees with the serial number on the outline drawings sent previously.

2. STORAGE

- A. If the pump is not to be installed immediately, it should be stored in a dry, clean area. Care should be taken to protect it from dust and moisture.
- B. Flange covers must be securely in place.
- C. Accompanying each pump will be one instruction manual, which should be properly identified and stored in a protected area.

3. SUCTION & DISCHARGE PIPING

The size and rating, of the suction and discharge flanges vary with different model numbers. Consult the outline drawings and specification sheet for your pump.

- A. The pump should be mounted as near to the supply tank as possible, while allowing sufficient working area around the pump for maintenance and disassembly.
- B. All piping must be supported independent of the pump. The piping should always line up with the pump flanges. Never draw the piping into place by the use of force at the suction and discharge connections as this may impose dangerous strains on the unit.
- C. The piping, both suction and discharge, should be as short and direct as possible. Avoid all unnecessary elbow, bends, and fittings as they increase friction losses in the piping. The size of the pipe

and fittings should be selected carefully and should be of sufficient size to keep the friction losses as low as practical.

- D. The use of elbows near the suction flange should be avoided. When used, elbows should have a large radius. A straight pipe run of at least ten times the pipe diameter is desirable between an elbow and the suction flange.
- E. Suction pipe should never be of a smaller diameter than the pump suction inlet. Reducers, if used, should be eccentric and preferably slope up to the pump to avoid creating air pockets in the piping.
- F. If reverse flow during shutdown is likely, it is recommended that a check valve be installed in the discharge line to protect the pump from possible reverse rotation.
- G. On initial installation of the pump, it is recommended that a temporary suction strainer be installed in the suction piping. This strainer may be removed after confirming that no additional foreign objects exist in the system. If a condition exists where foreign objects are present continuously, the strainer should be mounted permanently, with a differential pressure gauge installed to measure the drop across the filter.

In either case, the strainer should be 60 to 80 mesh and large enough in surface area to prevent flow-resistance and clogging. The strainer should be monitored frequently and cleaned on a regular basis, depending on the condition of the pumped liquid. On initial start-up the strainer should be checked for foreign objects soon after the system has started. Should a strainer become clogged, NPSH will be reduced, resulting in cavitation in the fluid end of the pump or at the motor bearings.

- H. Provisions should be made for pressure gauges in the suction and discharge piping. The gauges should be located as shown in Figure 1. The pressure gauges can be extremely helpful during start-up and are desirable for monitoring the performance of the pump.
- J. When the liquid level is below the pump level, a foot valve should be installed on the end of the suction line to prevent back flow from the suction line when the pump is not operating. The foot valve should be selected with a large port size to prevent a restriction on the suction side of the pump.

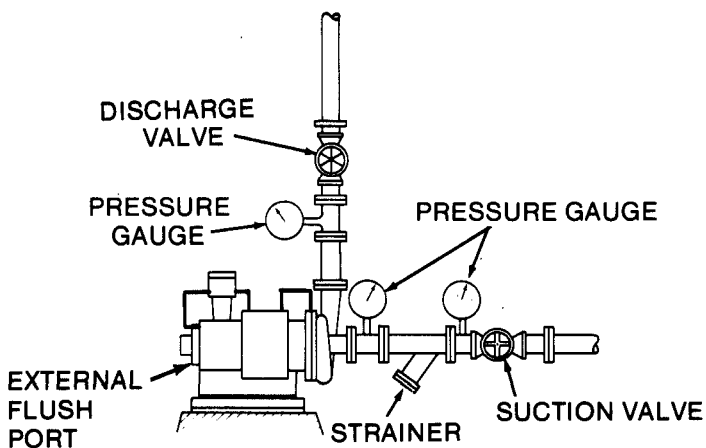

Figure 1. Typical Piping Arrangement

4. AUXILIARY PIPING

Depending on pumped fluid temperature and characteristics, a cooling (or heating) jacket maybe required and will be indicated on the outline drawing and specification sheet for the specific serial number pump Port sizes, temperature, flow and pressure requirements are also shown when required

5. ELECTRICAL WIRING (Recommended Electrical Circuit)

Normally, direct line starting is used for the canned motor pump because starting current is low and start-up time is short. If a low starting current must be maintained because of other existing electrical equipment or for some other reason, transformer starting or reactor starting may be used instead.

A Starter Type

A magnetic type contact switch should be used as the main control switch. This arrangement provides not only protection in the event of overload, but also thermal protection of the motor windings can be achieved by connecting the thermostats in series with the exciting coil of the switch. Properly sized circuit breakers and fuses must be used on all 3 phases. Motor full load amp value is shown on the specification sheet

B. Thermal Protection Circuit

A thermostat is located in the stator winding at a point where the winding temperature is the highest. Its purpose is to protect the motor windings from excessive heat build up. It is electrically connected in the stator as shown in Figure 2.

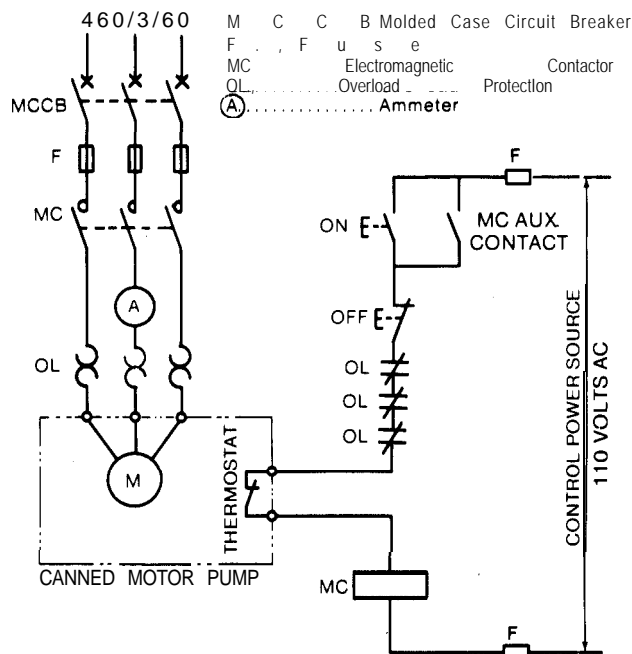
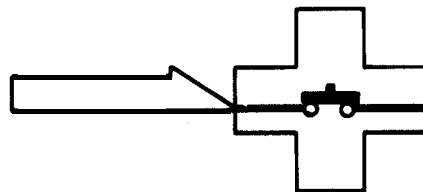

Figure 2. Recommended Circuit

- (a) The thermostat has normally closed (NC) contacts that open when the motor winding temperature reaches the rated value. Refer to specification sheet or Table 3 for thermostat operating temperatures



- (b) Maximum Thermostat Ratings: AC230V-0.5A

Thermostats may cycle rapidly when using a steam jacket. In this type of use, it is recommended that the current through the thermostat contacts be limited by using an auxiliary relay:

AC . . . 100V, 20-30 MA
DC . . . 24V, 10-25 MA

- C. The terminal box has two openings; the 3/4" NPT opening is for the thermostat leads and the 1" NPT opening is for the main power leads

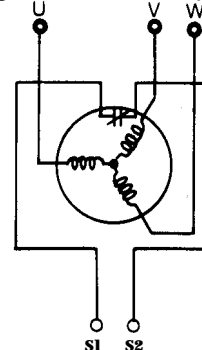

Figure 3. Standard SCMP Motor Winding & Thermostat Connection Diagram

Class of Insulation	Thermostat Operating Temperature
B	266°F ± 11°F
C	435°F ± 16°F

Table 3. Thermostat Operating Temperature

D. Wiring

- (a) When the phase relationship of the incoming power leads are known (i.e. R S T) make the connections as R-U, S-V, and T-W.

If the relationship is not known, random connection may be used. However, the direction of the motor rotation must be verified before pump operation using procedure described on page 5.

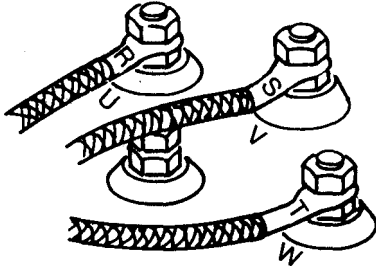

Figure 4. Main Power Connection

- (b) One thermostat is embedded in the stator windings. Make connections to S1 and S2 terminals to establish the protective circuit. If thermostats are not connected, overheating and burn out of windings may occur as a result of loss of pump flow, loss of suction, blocked discharge, running backwards, locked rotor, loss of cooling flow to jackets, etc.

For Power	U,V,W.
For Thermostat	S1, S2
For Spare	C1, C2

Table 5. Terminal Leads

WARNING

Do not use or loosen the nuts on the red painted terminals (C1 and C2).

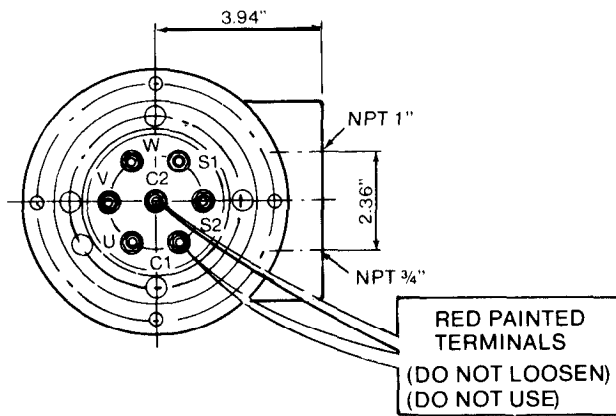

Figure 5. Terminal Plate

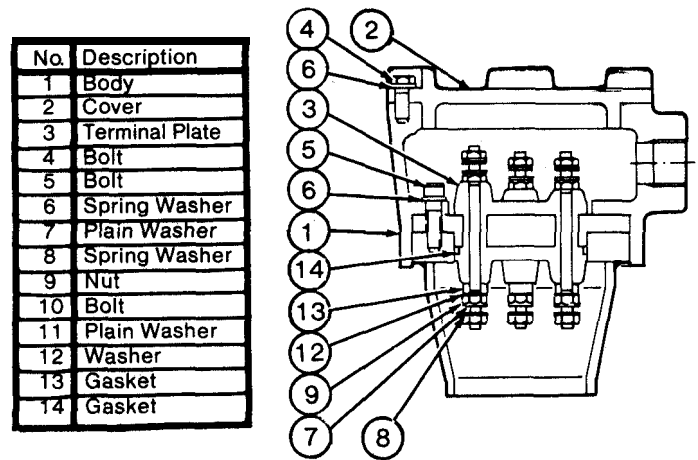

Figure 6. Terminal Box Cross Section

- (c) Inside the terminal box is a ground terminal. The terminal should always be used to ground the pump. Reference Figure 7.

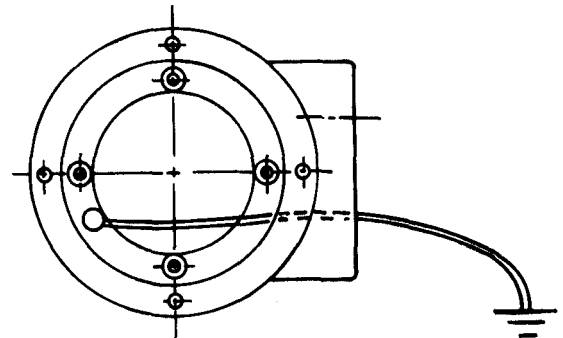

Figure 7. Terminal Box Grounding

- (d) "O" rings are used to seal the terminal posts and terminal plate 13 & 14. Fluid may leak into the stator cavity in event of rupture of the stator liner. The terminal plate "O" rings provide an additional seal to prevent fluid leakage into the junction box. If pumped fluid is hazardous, an adequate trap should be used in connecting cables and conduit to prevent leakage to the power source and additional damage.

E. Checking Insulation Resistance

After wiring has been completed, measure insulation resistance of the various circuits with a megger with a range of more than 500V.

- (a) Points at which insulation resistance is to be measured:
- Between the stator windings & ground.
 - Between the thermostat & ground.
 - Between the thermostat & stator windings

NOTE

The thermostat must be disconnected during insulation and resistance measurement if common power is used for the stator windings and thermostat circuits.

- (b) In all cases, the insulation resistance must be more than 2 M ohm.

NOTE

At time of shipment, insulation resistance is more than 100 M ohm.

WARNING

Operation of the pump must not be attempted until the section on operation has been read and thoroughly understood

If the overload relay or the thermostat trips during operation, inspect and determine the

real cause before restarting the pump. Correct the problem and then measure the resistance of the motor stator windings.

If the difference in resistance between any of the 3 stator windings is more than $\pm 5\%$, the motor stator is defective and must be replaced

WARNING

Do not apply power to a motor that has been determined defective, as serious injury may result

WARNING

When pump is installed outdoors, the terminal box and the electrical leads to the terminal box must be sealed so that water cannot enter the terminal box

II. OPERATION

WARNING

Do not operate pump when dry for more than 3 seconds

Do not operate under the following conditions :

- Blocked discharge and suction lines
- Below minimum flow rate.
- Insufficient NPSH (clogged suction strainer, low tank level, flow too high, etc)
- Inadequate flow rate of cooling water to cooling jacket
- Reverse rotation.

1. PREPARATORY PROCEDURES

WARNING

Do not attempt to operate the pump until the following checks have been performed.

A Motor Rotation - The correct direction is counter-clockwise as viewed from the pump end, or clockwise from the motor end. Rotation direction is checked by removing the bearing monitor and observing direction of shaft rotation when power is turned on for an instant

WARNING

Before removing the bearing monitor, be sure that there is no liquid or vapor in the pump.

Verify the direction of rotation by removing the bearing monitor from the rear to the motor. By directing a beam of light from a flashlight into the hole, the end nut can be seen. Apply power to the motor for an instant and visually check shaft rotation.

NOTE

If there is liquid in the pump, the direction of rotation can be confirmed by checking the pumping action for a few seconds. If the discharge pressure gauge indicates less than 70 percent of the design head at design flow, the motor is rotating in the wrong direction. If this is the indication, stop operation immediately, lock out electrical power, and switch any two power leads Pressure developed in reverse rotation may not be sufficient to push flow through the discharge system and cause zero flow with heat build up, loss of bearing cooling, and eventual failure

- B. Verify piping, valve location and position, electrical wiring and auxiliary piping
- C. Verify that the correct suction strainer is installed

2. PREPARATION FOR STARTING

- A Verify that suction & discharge valves are closed

- B. Turn on water to heat exchanger. Flow should conform to specification sheet requirements

WARNING

Never open suction valve until flush valve has been opened first and flush pressure verified

- C. Open flush valve allowing flush liquid to enter motor. Flush flow and pressure must conform to specification sheet Flush pressure must always be higher than suction pressure to prevent product liquid from entering motor.
- D. Open vent valve on heat exchanger.

WARNING

Extreme care must be exercised when opening this vent valve Protective gear for personal protection must be worn to avoid splashing of liquid exiting this valve

- E Open the suction valve, allowing the suction piping and pump to fill with liquid Open the discharge valve slightly to bleed air from the pump
- F. Start motor and run 15-20 seconds Repeat this jog starting 3 times This allows air to escape from the motor side, permitting additional liquid to fill the motor/pump.

3. START-UP PROCEDURE

- A. With the discharge valve slightly open, start motor and check to be sure that discharge pressure is approximately the value shown on the specification sheet Also check for any unusual noise or vibration.
- B. Open the discharge control valve, allowing the flow rate to increase to the design capacity.
- C. Verify the differential pressure across the suction strainer. If a large differential pressure exists, the strainer is clogging up The pump must be shut down immediately and the strainer cleaned

- D. The operation of the Sundyne Canned Motor Pump is quiet and smooth and it is sometimes difficult to determine if the pump is running.

During initial operation verify the following :

- (a) Compare flow rate, differential pressure and electrical current to the design specification
- (b) Occasionally the motor selected does not provide full curve protection. Therefore, the discharge control valve opening should be adjusted to maintain a flow rate so that current draw is below full load amperage value listed on the specification sheet
- (c) Check pump for any abnormal noise.
- (d) Open the discharge control valve gradually up to maximum required operating flow and listen for any increase in noise or vibration level. If an abnormal noise or vibration is detected as the discharge valve is opened further, without an accompanying increase in flow rate, cavitation is occurring in the pump. Operation of the pump under these conditions can cause severe damage to the internal parts of the pump.

WARNING

- Never operate the Sundyne pump under "cavitation" conditions
- Discharge throat cavitation can be heard on models 21A, 21B, 21C, and 22C when operating the pump at a flow rate beyond the end of the curve on the specification sheet This is not considered damaging to the pump. However, it is recommended that the pump capacity be restricted under the noise scope.
- Check heat exchanger difference in temperatures at the inlet and outlet piping
- When abnormal conditions occur, stop the pump and investigate.

4. ROUTINE INSPECTION DURING OPERATION

The following items should be checked on a routine schedule to verify normal pump operation.

- A Check discharge pressure against the original design specification.
- B. Checkammeters readings compared to the initial start-up readings
- C. Check for abnormal noise and any increase in vibration levels

- D. Check the bearing monitor to insure that it is in the safe operating range and has not actuated
- E Check the cooling water "in" and "out" line for a temperature differential.

5. MINIMUM FLOW RATE

Flow rates vary, depending on the type of pump, NPSH available and fluid characteristics shown on the specification sheet The flow rate specified is a minimum value. Pump should always be run above this rate.

6. EMERGENCY STOPPING

If the motor is wired correctly and the protective devices are in a serviceable condition, the pump will stop automatically if the temperature of the motor windings exceed the thermostat setting If this occurs, the cause could be as follows :

- Abnormally high temperature of the pumped fluid.
- Failure of the cooling system.
- Motor overload.

The pump also may stop because the overload relay has tripped This may indicate incorrect operating condition such as excessive flow or specific gravity. It may also indicate short circuit within the motor which may indicate that the stator liner has been ruptured. If the overload relay has tripped, the suction and discharge valves should be closed and cause of problem determined.

Determine the cause, perform corrective action and restart the pump

WARNING

Never restart motor until the cause is corrected. Measurement of winding resistance value described on page 5 should be done prior to determining whether stator windings have been damaged. Re-starting should be done only if winding check is satisfactory.

III. MAINTENANCE

1. PERIODIC CHECK

It is recommended that the pump be checked daily following initial start-up and then on a less frequent basis as satisfactory pump and system performance indicates. Monthly checks are usually sufficient thereafter if system operation is stable. Check of the following points is recommended.

- BEARING MONITOR

The bearing monitor has proven to be 98% effective in indicating bearing wear so that replacement can be made before contact between rotor and a stator liners requires more extensive repairs. It is an effective predictive maintenance tool which allows scheduling of maintenance.

- PUMP PERFORMANCE

Pump differential pressure, flow, and amperage draw should be near specification sheet values.

- CONDITION OF SUCTION STRAINER

Should be verified to assure that NPSH is not being reduced.

- UNUSUAL NOISE OR VIBRATION

May indicate internal wear or cavitation due to insufficient NPSH.

- ELECTRICAL CHECK

Should be made yearly to assure that insulation resistance is over 100M ohms with 500 V megger and that unbalance of resistance between phases is within 5%.

- COOLING OR HEATING JACKET

Should be checked periodically if there is a tendency for corrosion or clogging.

2. BEARING MONITOR

A. Construction - The bearing monitor is composed of a gauge that indicates a safe or unsafe operating condition of the motor bearings and a pressurized sensor. There are two types of bearing monitors. The MS-01 is pressurized with argon to approximately 142-170 psig and the second type, the MS-02, is sealed at atmospheric pressure.

B. Function - The monitor is used to determine the early stages of bearing wear and corrosion of the rotor and stator cans.

During normal operation, the pointer of the bearing monitor indicates in the safe operating zone.

When the bearing wears or the sensing tip is corroded, the sensor ruptures and the pointer moves into the red zone. The MS-01 type monitor which is pressurized will discharge, allowing the pointer to move into the red zone. With the MS-02 monitor, the ruptured sensor will allow liquid to enter the monitor, causing the pointer to move into the red zone. The type of monitor used is printed on the face of each gauge and on the spare parts list for specific unit serial number.

If the pointer enters the red zone while in operation, stop the pump as soon as possible and disassemble. The pump must be drained and made safe for opening to atmosphere before removing bearing monitor. By inspecting the bearing monitor sensing tip, some clues should be obvious to expected findings in the pump. In the case of corrosion, check the degree of corrosion in the rotor can and also in the stator can. If necessary, one or both may need to be replaced with different materials, or they both may need to be replaced with different materials, or the cause of corrosion otherwise corrected. Wear on either face of the sensor tip indicates excessive thrust wear, and wear on the outside diameter indicates excessive wear of the journal bearing.

When the thrust bearing in the rear position wears, the impeller may make contact with the liner disc before the dimensions listed above are reached.

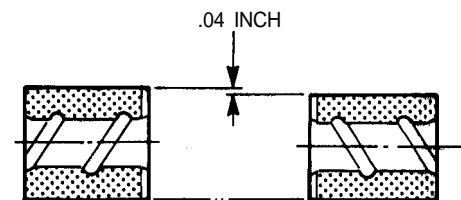

BEARING AT REAR SIDE (LARGE DIA WITH GROOVES) BEARING AT FRONT SIDE (SMALL DIA WITH GROOVES)

Figure 9. Front (Impeller End) and Rear Bearing Differences

When replacing the bearings, the shaft sleeves and thrust washers should also be replaced if any visible damage can be seen.

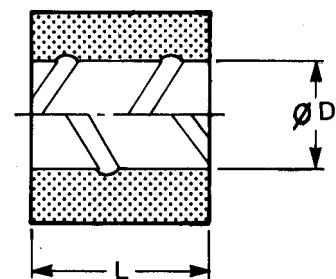

Figure 10. Bearing Wear Limitation

3. BEARING REPLACEMENT

Bearing replacement kits recommended in spare parts list contain all gaskets, "O" rings, tab washers, bearings, shaft sleeves, thrust washers as well as instructions measurement gauge and wrenches required for replacement. The measurement gauges allows inspection to determine amount of wear and need for replacement. Bearing wear limits are also shown in Table 6. Front and rear bearings are not interchangeable. Differences are shown on Figure 9.

Motor Frame Number	Max Value Inside Dia D (inches)	Min. Value Overall Length L (inches)	
		Front-Side Bearing	Rear-Side Bearing
A1, A2, A3	1.11	1.54	1.54
B1, B2, B3	1.35	1.93	2.32

Table 6. Bearing Wear Limit

If montitor has been tripped, it cannot be repaired and must be replaced with a new one. If the bearing montitor has been tripped as a result of bearing wear, the end nut must also be replaced. These parts are contained along with instructions in the bearing monitor replacement kits which is recommended as a spare part.

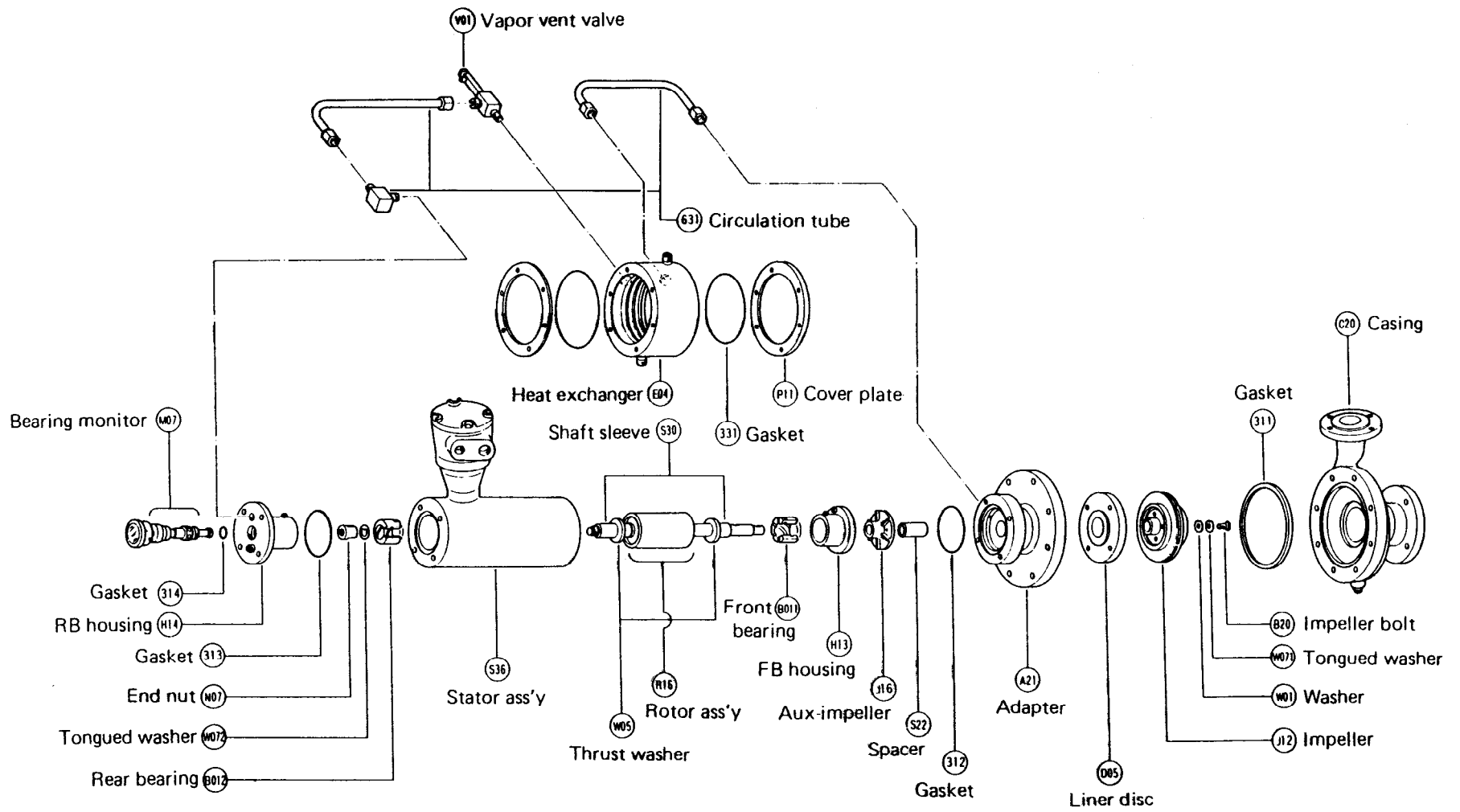

Figure 11. Exploded view of Slurry type

Page Intentionally Left Blank

IV. TROUBLESHOOTING

CORRECTIVE ACTION	TROUBLE	PROBABLE CAUSE
Check connection, motor winding & fuse.		Insufficient power supply.
Check		Faulty thermostat
Check insulation resistance and dryness of motor.		Deterioration of insulation.
Overhaul. Check for scuffing due to seizure of bearings or contact of rotor assembly.		Locked Rotor.
Repair or replace stator assembly and rotor assy. Change material of can.		Corrosion of can.
Repair or replace as needed. Change material.		Corrosion of impeller.
Replace. Change material if there is corrosion.		Corrosion or wear of shaft sleeve.
Replace.		Bearing wear.
Replace bearing(s).		Contact of impeller with casing.
Readjust thrust balance.		Incorrect thrust balance.
Repair, straighten shaft		Bent shaft
Check system piping. Eliminate cause, repipe.		Vibration or surge of piping system.
Check system piping system and strainer.		Entering of foreign object.
Recheck direction of rotation & correct connection.		Improper motor rotation.
Clean and eliminate cause of clogging		Clogged impeller.
Reselect pump. Recheck system piping at discharge side.		Excessive resistance at discharge side (head).
Return to specified limit		Higher liquid viscosity than that specified.
Return to specified limit		Specific gravity of liquid higher than that specified
Close discharge valve till specific flow is obtained		Excessive flow rate.
Check and clean. Also check hollow shaft.		Blockage in circulation system
Secure sufficient flow. Perform by-pass operation as the case may be.		Operating at shut-off or flow rate too low
Increase cooling water flow.		Operating at shut-off or flow rate too low
Reprime pump		Inadequate priming.
Perform air bleeding thoroughly through vent		Incomplete air bleeding
Review and correct suction condition to satisfy NPSH conditions.		Insufficient NPSH (cavitation).
Take proper step to prevent air from entering pump.		Air entering suction side of pump.
Readjust piping to prevent air pockets		Air or vapor pockets at suction side.
Check and clean. It may be traced to strainer.		Clogged suction pipe.
Prior to using pump for any other application. Consult factory.		Change of working conditions (use of pump for other application)
Check cooling water flow rate.		Insufficient cooling water
Clean the inside of jacket		Build up of scale in jacket

Table 8. Troubleshooting Chart

Page Intentionally Left Blank

V. DISASSEMBLY & REASSEMBLY PROCEDURE



STEP 1

This pump can be removed from the system by either disconnecting the pump at the flange connections or by leaving the pump casing installed and backing out the motor.

WARNING

Before any work is performed on the pump, it must be depressurized, drained, electrical disconnected, and pump made safe from both environmental and physical hazards

NOTE

When separating pump casing and motor, care must be taken not to damage impeller and/or inducer.

STEP 2

Remove impeller by unlocking impeller washer and unscrewing impeller bolt. Impeller bolt has right hand threads. To secure the open type impeller from turning, an adjustable wrench may be fitted to one of the impeller blades. For closed impellers, a strap wrench can be wrapped around the impeller shroud.

Slide impeller from shaft followed by the pump gasket.

Particular attention is necessary not to misplace, impeller and shaft sleeve drive keys.

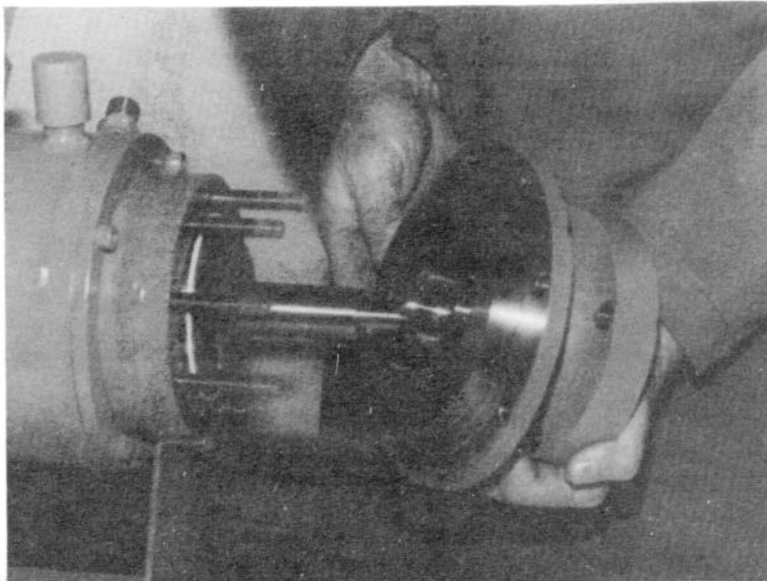

STEP 3

If impeller is closed type, clearance of fixed orifice on front and back sides compared to case and liner disc should be checked for rubs. If there is wear, rework or replacement should be done if clearance is more than .025 inches on the diameter.

Remove adaptor housing by loosening the hexagonal nuts.

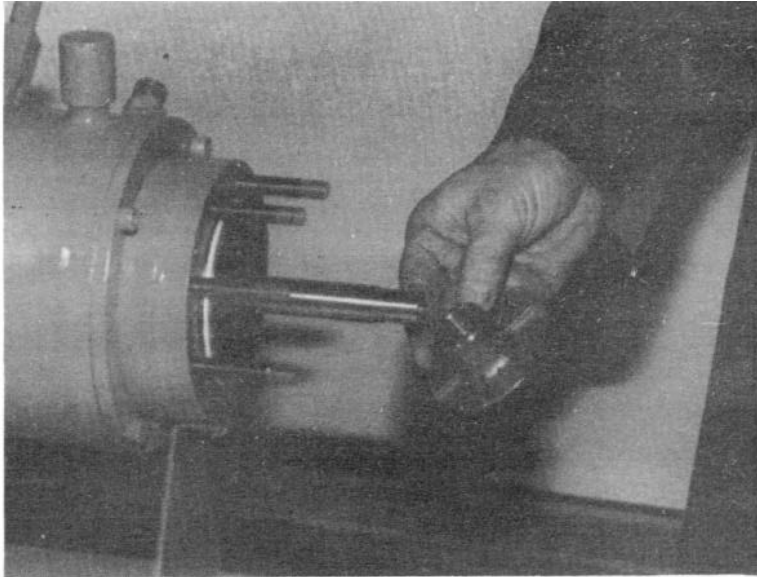

STEP 4

Remove the spacer sleeve followed by the auxiliary impeller.

NOTE

STEP 5

Remove the guide disc by loosening the four (4) cap screws.

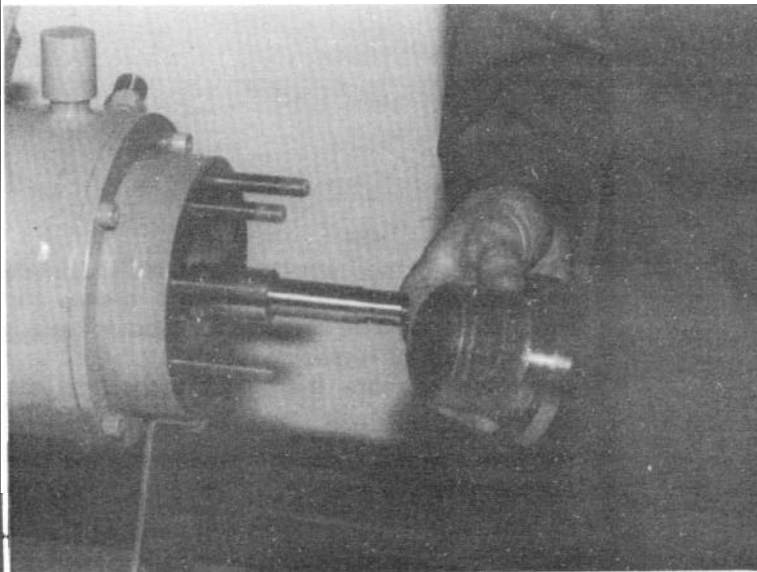
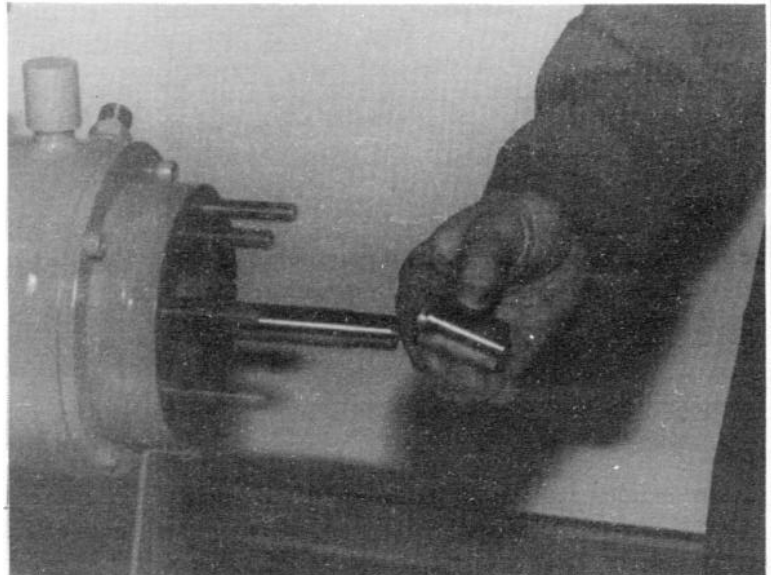

STEP 6

Remove the bearing housing from motor by loosening the cap screws.

NOTE

The rotor is supported by the bearings (bearing housings). Therefore, special care must be used when sliding out the bearing housing.

The set screw holding the bearing secure must always be in the up position when reassembled.

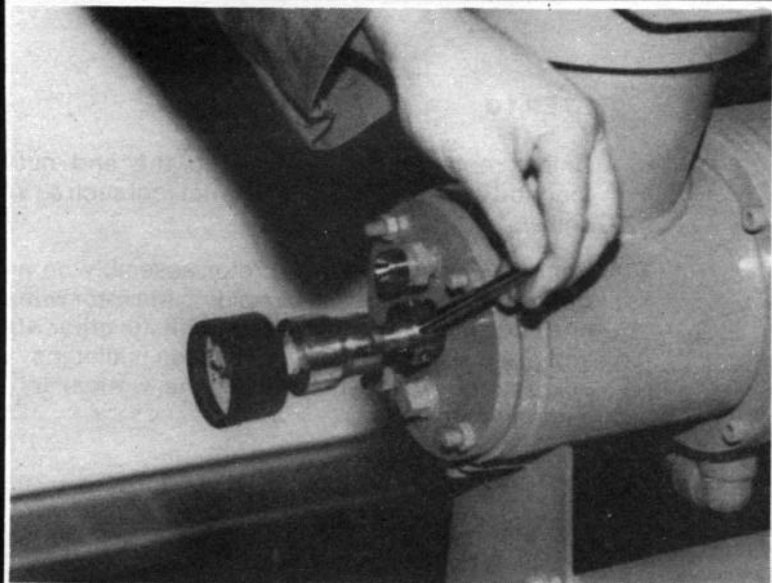

STEP 7

Care should be taken when removing or installing the bearing monitor since it must be positioned in a eccentric hole in the end of the motor shaft. Bearing monitor can easily be removed or installed by tilting the monitor at a slight angle after loosening.

Do not use sealing tape on threads of bearing monitor.

STEP 8

Remove the rear bearing housing by loosening the nuts and pull the housing out board.

NOTE

Upon reassembly the rear bearing housing should be positioned so that the vent fitting is located in the up position. On some housings, the vent fitting is not used. In this case, align the bearing set screw to the up position.

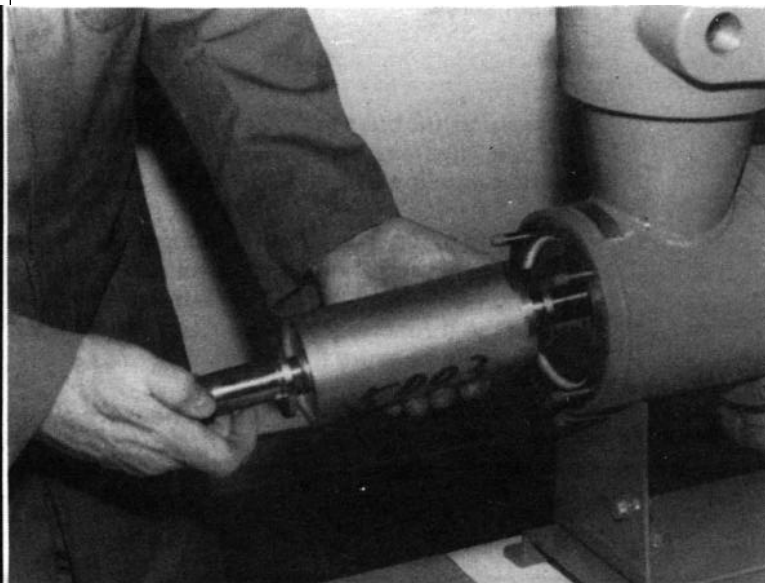
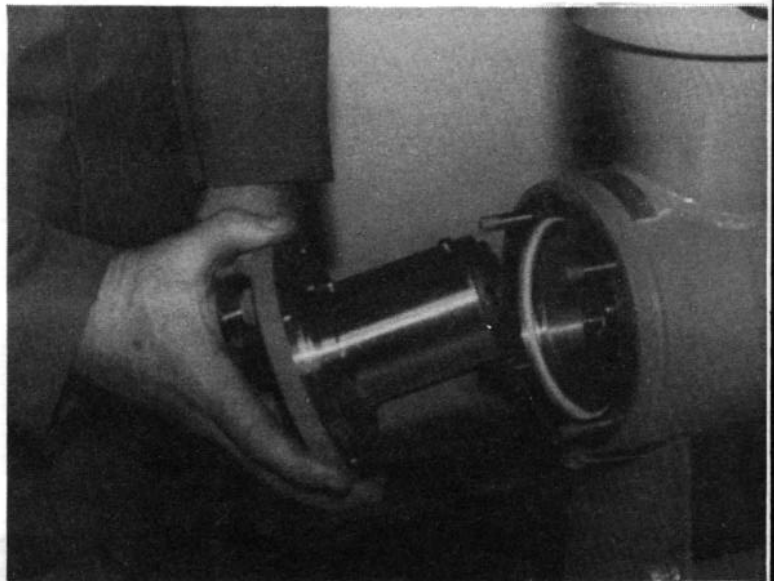

STEP 9

Remove rotor assembly by sliding and lifting so that the rotor and/or stator is not damaged during this step.

NOTE

The rotor assembly should be disassembled and assembled on a clean padded work bench. The rotor should never be placed in a vice or other clamping mechanisms.

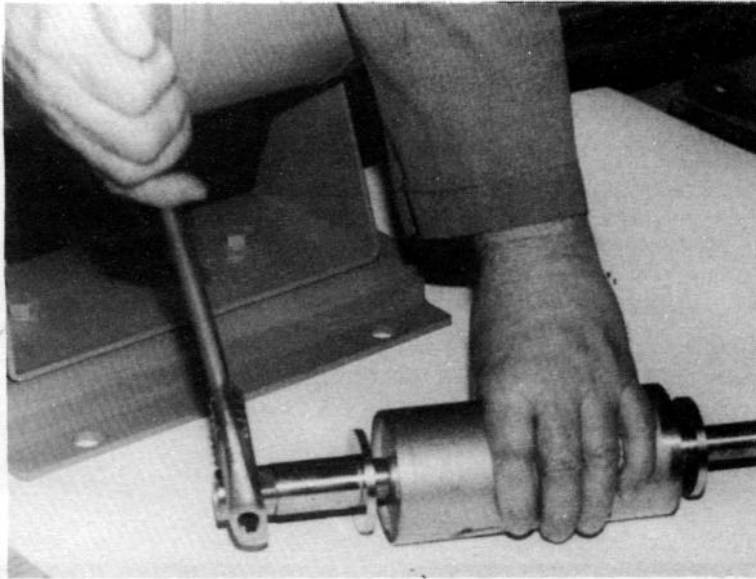

STEP 10

Unlock end nut by bending up the end nut tongued washer using a sharp flat tool such as a chisel.

Remove end nut by laying rotor assembly on a well padded work bench by holding the rotor with one hand and turning the wrench with the other. If end nut is extremely tight, a rawhide mallet may be required to tap the end of the wrench for loosening

NOTE

The end nut has left hand threads Excessive torque applied to motor shaft should be avoided as shaft may become bent Upon reassembly of the end nut the tongued washer must be held concentric with the motor shaft while tightening the end nut If the tongued washer is allowed to extend beyond the shaft sleeve diameter, the bearing (bearing housing) cannot be installed over the shaft and bearing may be damaged.

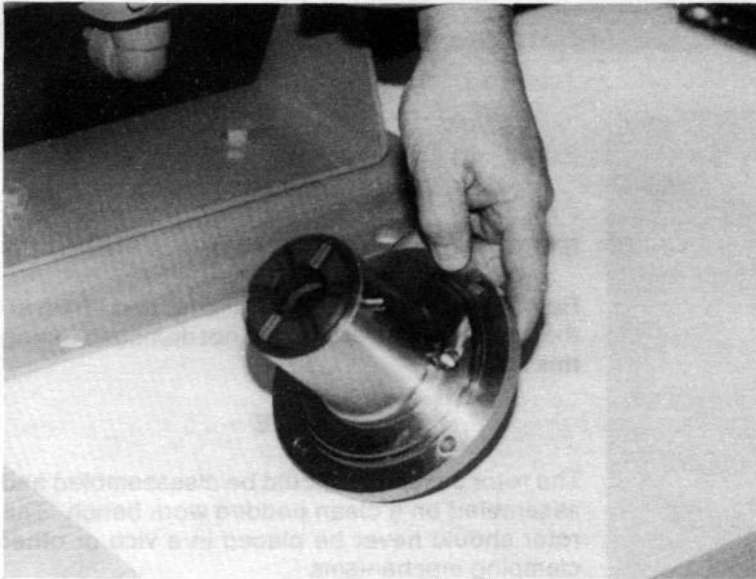

STEP 11

Remove bearing from bearing housing by loosening set screw.

NOTE

If the pump has been in service any length of time, the bearings may be difficult to slide out of the bearing housing without external force.

If pump is being disassembled to check bearing wear, the bearings need not be removed from the bearing housing to check the radial wear. However, if the thrust wear is evident an attempt must be made to measure this wear.

When checking bearing wear, measurements should always be recorded



STEP 12

If external force is required, secure bearing housing in a padded vice. By tapping the bearing with a drift punch and hammer, the bearing will slide from the housing. When this method of removal is used the bearing usually is cracked upon its removal, rendering it scrap.

NOTE

When installing new bearings, make sure the small protective sheet metal plate is placed in the slot in the bearing, then tighten the set screw lightly.

NOTE

All internal bolts and screws are made of alloy steel. Therefore, over torquing is not recommended.

REASSEMBLE PUMP IN REVERSE ORDER

Before assembling the pump, inspect all components to insure that they are in serviceable condition. If the pump was disassembled for inspection only, the "O" rings and pump case gasket should always be replaced regardless of their condition.

- When installing the front and rear bearing housing, tighten the bolts in a criss-cross pattern until the housing is felt to be in position. Wait 15 minutes to allow the Teflon® "O" ring to cold flow; then tighten a second time.
- When installing the thrust washers on the motor shaft, the plated surface always faces to the outside.

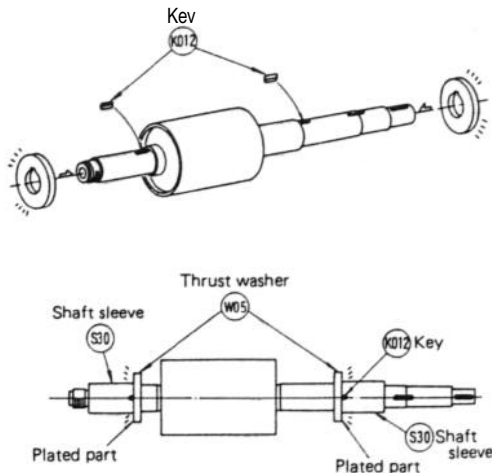

CLEANING THE HEAT EXCHANGER

When cleaning the inside of the heat exchanger following procedure should be followed:

- Disassemble the pump as instructed in the previous section.
- Loosen bolts (131) followed by the cover plate (P11) and the "O" rings.

NOTE

Do not reuse the "O" rings.

- If deposits are found in the internal, more frequent cleaning is necessary. Build-up of contaminants reduces the efficiency of the jacket and can cause the thermostats to break contact and result in motor shut down.
- Clean the inside of the heat exchanger using a high pressure water hose. Do not install if the jacket has deteriorated.
- Reassemble the heat exchanger in the reverse order. When tightening the bolt (131) tighten approximately 2 turns, then switch 180° to the other side and repeat. Then draw the cover plate evenly against the "O" ring preventing "O" ring extrusion. Check in and out port for proper location before tightening the bolts completely.

INSTALLING END NUT AND BEARING MONITOR

When installing the end nut on the motor shaft, the complete rotor assembly must be removed from the stator.

NOTE

Do not attempt to replace the end nut when the unit is assembled.

With the rotor removed from the stator and placed on a padded work area, the end nut can be removed by unlocking the tongued washer and turning the end nut clockwise (left hand threads) to loosen.

On reassembly the opposite is required (counterclockwise) to tighten. As the end nut is being tightened, the tongued washer must be held concentric with the motor shaft. If the tongued washer is allowed to extend beyond the shaft sleeve diameter, the bearing housing cannot be installed on the shaft and the bearing may be damaged.

The tongued washer must be firmly bent to the flat on the end nut without damaging the other shaft components.

When installing the bearing monitor, hold the monitor at a slight angle and pull back the large circular nut on the bearing monitor. Position the sensing tip into the eccentric hole of the end nut.

With the monitor positioned properly (aligned with the motor), screw the large nut several turns into the bearing housing. If resistance is felt during the first 1 or 2 turns, do not force the nut, but back off and investigate.

NOTE

Do not use Teflon™ tape or sealing compound on the threads of the bearing monitor. This causes misalignment of the sensor tip and can result in malfunction of the bearing monitor.

The bearing monitor, when correctly installed will be in perfect alignment with the motor end of the pump.

- The impeller should be checked for free rotational movement as well as slight axial movement. If impeller is locked and cannot be rotated, remove the bearing monitor and inspect for possible causes.

NOTE

Bearing monitors that have been dropped or damaged in shipment should never be used.

VI. RECOMMENDED SPARE PARTS

Spare parts for the Sundyne Canned Motor Pump are available in 2 (two) convenient kits, or can be ordered individually as shown in Table 9 and 10.

The Bearing Replacement Kits contain all of the components normally required for replacement of bearings, shaft sleeves, and thrust washers Packaged in a box with cross section drawings, disassembly photographs and special tools Bearings should be replaced periodically as routine maintenance, prior to wearing out (or tripping the bearing monitor) in order to prevent damage to pump or motor components

BEARING REPLACEMENT KIT RKI CP _____

NAME	ITEM NO.	QUANTITY PER UNIT
Front Bearing	BO11	1
Rear Bearing	BO12	1
Shaft Sleeve	S30	2
Thrust Washer	W05	2
Washer, Impeller	W01	1
Tongued Washer	W071	1
Tongued Washer	W072	1
*Gasket, Jacket Body	331	2
Gasket, Motor	331	1
Gasket, Motor	312	1
Gasket Pump	311	1
Liner Ring	R10	1

* Heat exchanger gaskets are not included in the bearing replacement kit but are available separately.

Table 9. Bearing Replacement Kit

The Bearing Monitor Kit is required only if the bearing monitor has been tripped due to excessive bearing wear. It should then be installed together with a bearing replacement kit

BEARING MONITOR REPLACEMENT KIT RK2CP _____

NAME	ITEM NO.	QUANTITY PER UNIT
End Nut	NO7	1
Tongued Washer	W072	1
Bearing Monitor	M07	1
Gasket, Bearing Monitor	314	1

Table 10. Bearing Monitor Replacement Kit

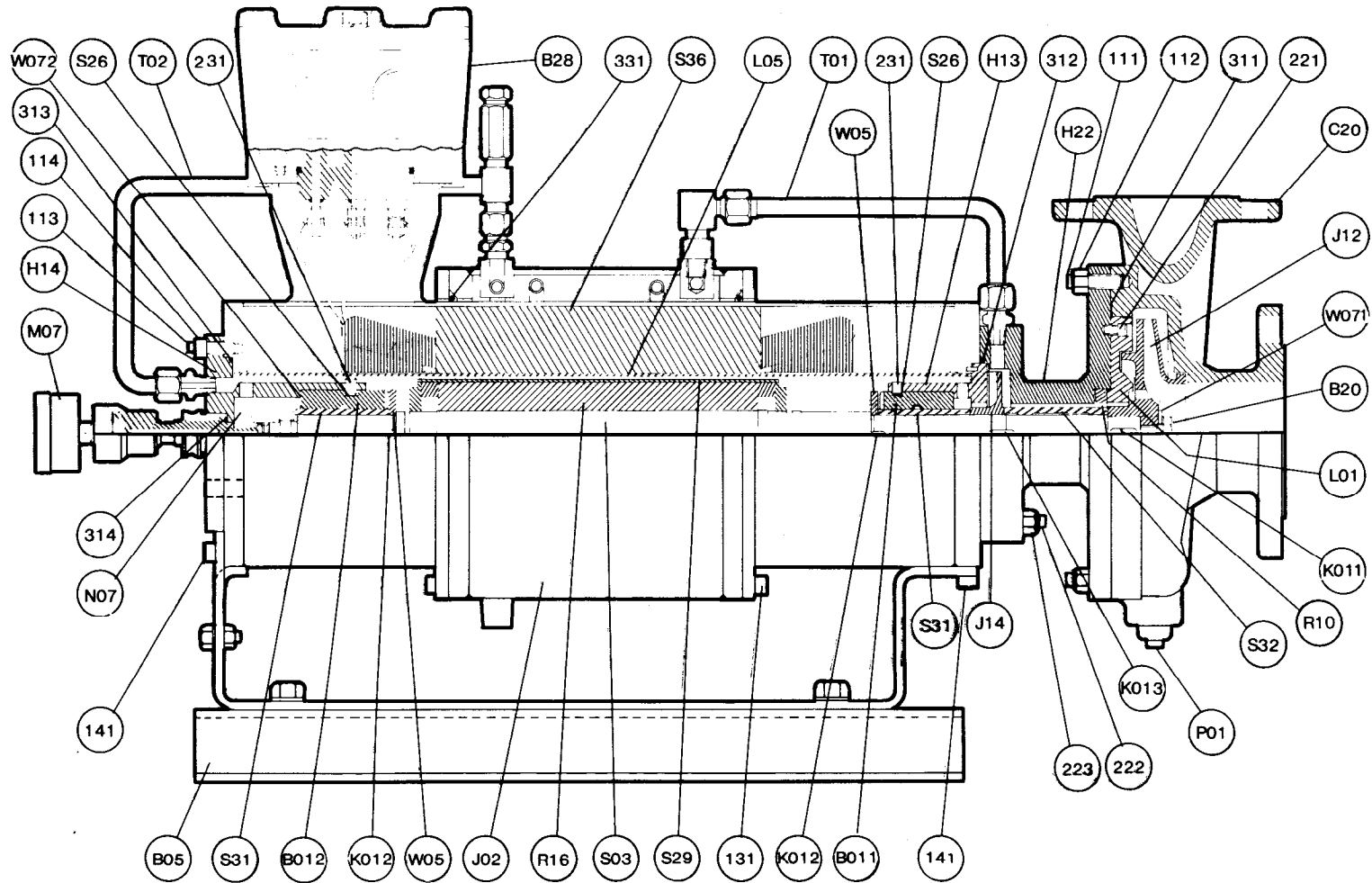

VII. CROSS SECTIONS

SUNDYNE CANNED MOTOR PUMP
SGM Series- Model HS
SUNDSTRAND 
FLUID HANDLING

CERTIFIED CORRECT

BY _____ DATE _____

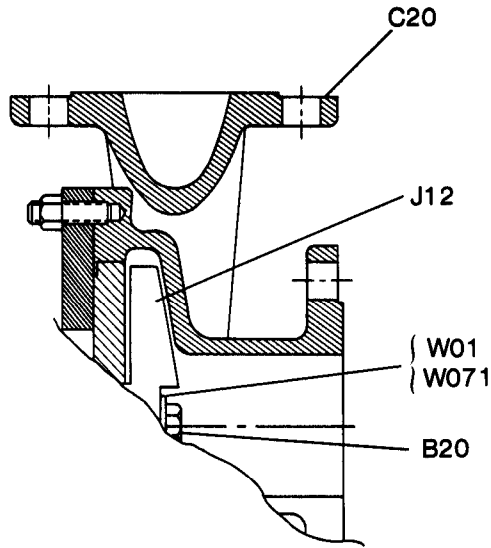

OPEN IMPELLER
(21 A, 21B, 21C, and 22C Models)

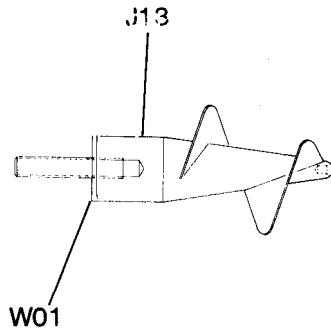

INDUCER
(Optional)

NO	PART NAME	QTY
B011	Bearing	2
B012	Bearing	1
B05	Base Assembly	1
B20	Impeller Bolt	1
B28	Junction Box	1
C20	Pump Case	1
H13	Front Bearing Housing	1
H14	Rear Bearing Housing	1
J02	Heat Exchanger	1
J12	Impeller	1
J13	Inducer Assembly (Optional)	1
J14	Auxiliary Impeller	1
K011	Key	1
K012	Key	2
K013	Key	1
L05	Stator Liner	1
M07	Bearing Monitor	1
N07	End Nut	1
H22	Adaptor Housing	1
R16	Rotor Assembly	1
S03	Shaft	1
S26	Bearing Set Plate	1
S29	Rotor Liner	1
S31	Shaft Sleeve	2
S36	Stator Assembly	1
W01	Inducer Washer	1
W05	Thrust Washer	2
W071	Impeller Washer	1
W072	Tongued Washer	1
111	Stud	8
112	Nut	8
113	Stud	4
114	Nut	4
131	Bolt	12
141	Bolt	2
221	Bolt	4
222	Stud	6
223	Nut	6
231	Set Screw	2
311	Gasket	1
312	"O" Ring	1
313	"O" Ring	1
314	"O" Ring	1
331	"O" Ring	2
S32	Shaft Spacer	1
T01	Circulation Tube Assembly	1
T02	Circulation Tube Assembly	1
P01	Plug	1
R10	LINER RING	1
L01	Liner Disc	1

SUNDYNE CANNED MOTOR PUMP
SGM Series - Model HS

SUNDSTRAND 
FLUID HANDLING

(Nikkiso Non-Seal Pump)

CERTIFIED CORRECT

BY

DATE

CUSTOMER _____ SERIAL NO. _____

WARNING

Vent all air and vapors to safe point prior to start up
Failure to do so may block circulation flow through heat exchanger resulting in excessive heat and wear of motor. A mixture of flush liquid and/or pumped liquid will exit vent opening and must be handled safely.

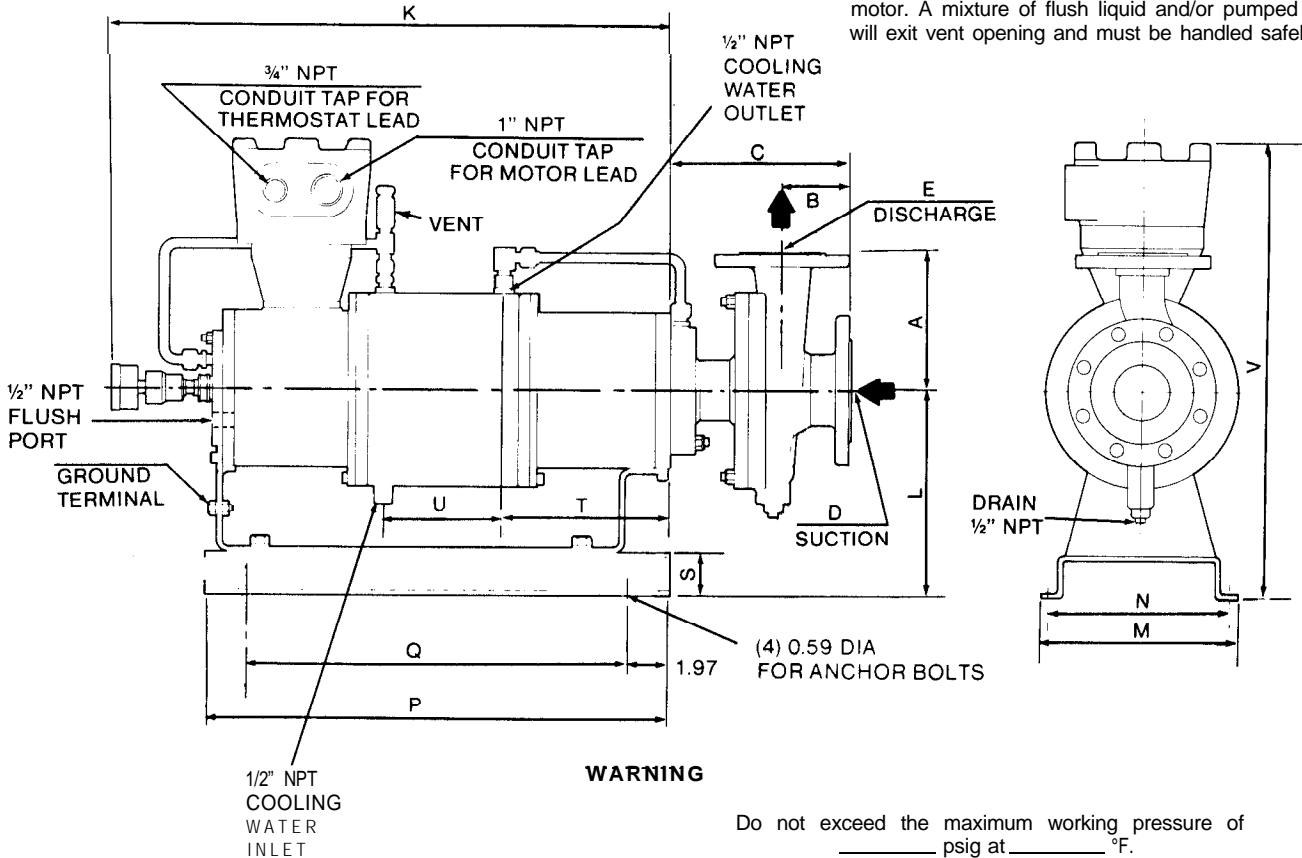

WARNING

Control flush to the rear of the motor to ----- g p m prior to start up and during operation Flush supply pressure of ----- psig above suction pressure is required.

Do not exceed the maximum working pressure of ----- psig at ----- °F.

Cooling water to heat exchanger must be gpm based on a water temperature of 95°F.

PUMP

ENGLISH (INCHES)

MOTOR

ENGLISH (INCHES)

PUMP MODEL	A	B	C	NOMINAL PIPE SIZE		MOTOR SIZE	K	L	M	N	P	Q	S	T	U	V
				"D" SUCTION	"E" DISCHARGE											
21A	6.50	4.0	8.26	2	1	A1 0.75	15.94	9.45	8.27	7.28	10.08	6.14	1.57	3.09	0.98	20.00
21B	6.50	4.0	8.22	2	1	A2 1.5	17.28	9.45	8.27	7.28	11.42	7.48	1.57	2.07	3.35	20.00
21C	6.50	4.0	8.24	2	1	A3 2.2	18.39	9.45	8.27	7.28	12.52	8.58	1.57	3.17	3.35	20.00
22A	6.50	4.0	8.61	3	1½											
22B	6.50	4.0	8.50	2	1											
22C	6.50	4.0	8.30	2	1											
22D	6.50	4.0	8.64	2	1											
23A	6.50	4.0	9.00	3	1½											
23B	6.50	4.0	8.97	3	1½											
23C	6.50	4.0	8.66	3	1½											
24B	8.25	4.0	9.45	3	2											

SUNDYNE®
CANNED MOTOR PUMP
SGM SERIES

TYPE HS

SUNDSTRAND 
FLUID HANDLING

(Nikkiso Non-Seal® Pump)

CERTIFIED CORRECT

USER _____
ITEM NO. _____
LOCATION _____
PURCHASE ORDER NO _____
MODEL NO. _____
WEIGHT _____

FLANGES

ANSI FLANGE RATING
150# RF
300# RF

BY _____ DATE _____
REVISION _____ DATE _____

CUSTOMER _____

SERIAL NO. _____

WARNING

Vent all air and vapors to safe point prior to start up. Failure to do so may block circulation flow through heat exchanger resulting in excessive heat and wear of motor. A mixture of flush liquid and/or pumped liquid will exit vent opening and must be handled safely.

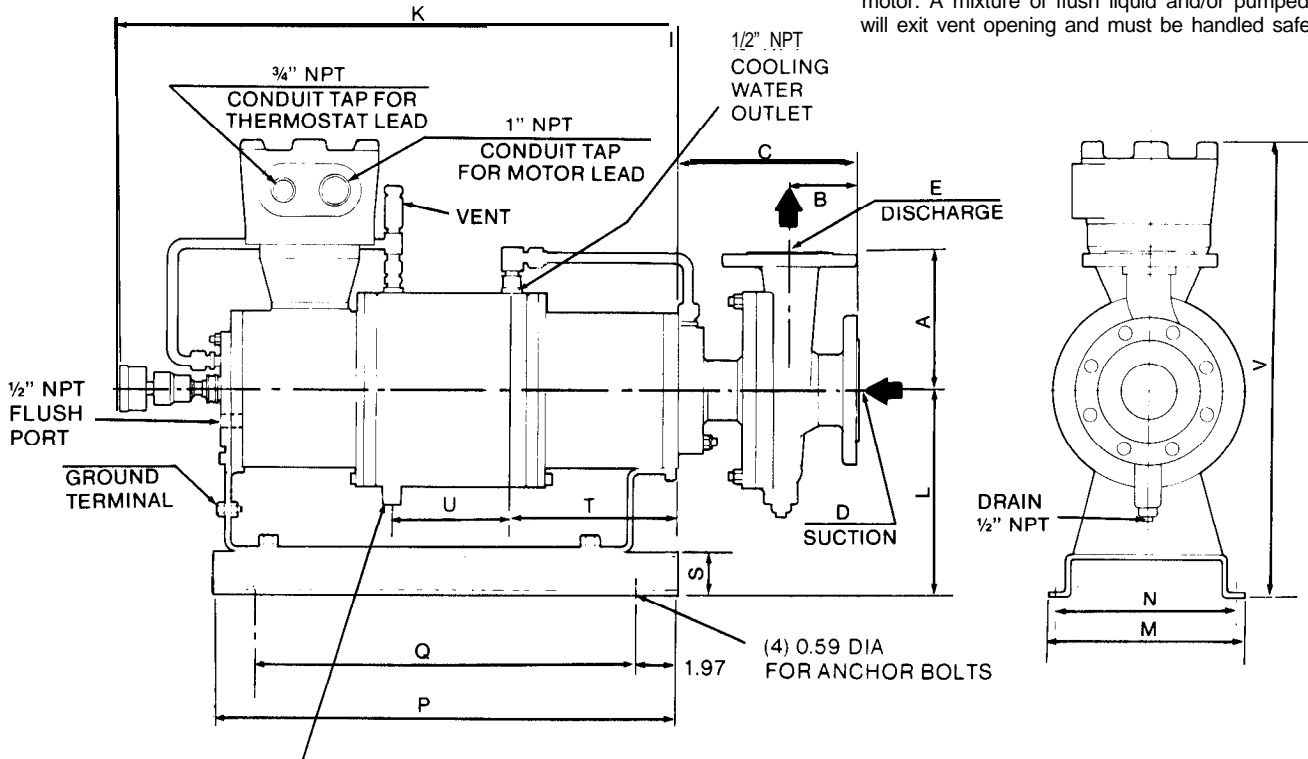

WARNING

Do not exceed the maximum working pressure of _____ psig at _____ F.

Cooling water to heat exchanger must be _____ gm based on a water temperature of 95°F.

Control flush to the rear of the motor to _____ gpm prior to start up and during operation. Flush supply pressure of _____ psig above suction pressure is required.

PUMP

MOTOR

ENGLISH (INCHES)

PUMP MODEL	A	B	C	NOMINAL PIPE SIZE		MOTOR SIZE	K	L	M	N	P	Q	S	T	U	V	
				"D" SUCTION	"E" DISCHARGE												
22C	6.50	4.0	8.50	2	1	B1	3.7	20.67	10.24	11.02	10.04	16.38	12.44	1.97	4.07	4.13	21.57
22D	8.50	4.0	8.83	2	1	B2	5.5	21.85	10.24	11.02	10.04	17.56	13.62	1.97	5.26	4.13	21.57
23B	6.50	4.0	9.17	3	1 1/2	B3	7.5	23.58	10.24	11.02	10.04	19.29	15.35	1.97	6.99	4.13	21.57
23C	6.50	4.0	8.86	3	1 1/2												
23D	8.50	4.0	9.01	3	1 1/2												
24B	8.25	4.0	9.64	3	2												
23C	8.25	4.0	9.63	3	2												

USER _____

ITEM NO _____

LOCATION _____

PURCHASE ORDER NO _____

MODEL NO _____

WEIGHT _____

FLANGES

ANSI FLANGE RATING

150# RF

300# RF

SUNDYNE[®]
 CANNED MOTOR PUMP
 SGM SERIES
 TYPE HS
SUNDSTRAND 
 FLUID HANDLING
 (Nikkiso Non-Seal[®] Pump)
 CERTIFIED CORRECT

BY _____ DATE _____

REVISION _____ DATE _____

CRITICAL STARTUP CHECK LIST

KNOW YOUR MACHINE

Prior to start-up of the Sundyne Canned Motor Pump, carefully review the specification sheet, outline drawing performance curves, and instruction manual. It is important that you become familiar with the pump configuration before starting and operating the pump.

MOTOR INSTRUCTIONS

Follow installation and starting instructions

CHECK MOTOR ROTATION

Rotation must be CW looking at end of motor.

PREPARATION FOR STARTING

Read and understand the section "II. OPERATION" on pages 7 and 8.

CHECK

Check head rise, flow rate, and power consumption against pump specification sheet. Check that specific gravity, viscosity and NPSH are in accordance with the specification sheet. These conditions will significantly alter performance of the pump.

MANUFACTURERS WARRANTY

The Manufacturer warrants that its pumps are not defective in material or workmanship and that, when properly installed and operated, they will perform in accordance with the Manufacturers written proposal, if any. Subject to the preceding sentence and except as otherwise expressly stated herein, THE MANUFACTURER MAKES NO REPRESENTATION OR WARRANTY OF ANY KIND, EXPRESS OR IMPLIED, AS TO MERCHANTABILITY, FITNESS FOR ANY PARTICULAR PURPOSE, OR ANY OTHER MATTER WITH RESPECT TO THE GOODS. The Manufacturer shall not be liable for any damages except as set forth herein.

Parts returned to the manufacturer and determined by the Manufacturer, in its sole discretion, to be defective in material or workmanship within one year of start-up (or within six months of start-up in the case of two or three shift operation) or within 18 months of delivery to Customer, whichever occurs first, will, at the Manufacturers sole option, be repaired or replaced free of charge, f.o.b. Arvada, Colorado. Replaced parts are the property of the Manufacturer. Equipment and accessories not manufactured by the Manufacturer are warranted only to the extent of and by the original manufacturers warranty.

Any such repair or replacement will be performed by the Manufacturer within a reasonable time of the pumps return. This warranty is voided by repairs made by the Customer, except in cases of emergency where operational safety requires such emergency repairs and the Customer promptly notifies the Manufacturer of such emergency repairs.

Manufacturer assumes no responsibility for damage resulting from improper installation, improper operation, normal wear and tear, operation under improper conditions, operation with unsuitable liquid, corrosion due to improper metal combination, electrical or electrochemical effects, or improper process design.

Manufacturer shall not be liable for consequential or incidental damages of any kind, which are hereby expressly excluded. The Customer assumes responsibility for all personal injury and property damage resulting from the handling, possession or use of the pumps by the Customer and the Customer waives and agrees not to sue upon, and releases the Manufacturer from any and all liability for the Manufacturers negligence, breach of contract other than as provided herein, breach of warranty other than as provided herein, strict liability in tort, and for other tort.

PARTS & ACCESSORIES SAFETY WARNING

Sundstrand Fluid Handling Corporation manufactures Sundyne and Sunflo pumps and compressors to exacting internal Quality Management System Standards (ISO9001 & 9002), as certified and audited by Lloyd's Register Quality Assurance Limited.

Genuine Sundstrand Parts and accessories have been specially designed and tested for the use with these products to ensure continued product quality and performance. As Sundstrand Fluid Handling cannot test all parts and accessories sourced from other vendors, incorrect design and/or fabrication of such parts and accessories may adversely effect the performance and safety features of these products. FAILURE TO PROPERLY SELECT, INSTALL OR USE AUTHORIZED SUNDSTRAND FLUID HANDLING PARTS AND ACCESSORIES IS CONSIDERED MISUSE, AND DAMAGE OR FAILURE CAUSED BY MISUSE IS NOT COVERED BY SUNDSTRAND FLUID HANDLING WARRANTY

Additionally, modification of Sundstrand Fluid Handling products or removal of original components may impair the safety of these products and their effective operation,



Sundstrand Fluid Handling, 14345 W. 64th Avenue, Arvada, Colorado USA • +1-303-425-0800 FAX: +1-303-425-0896 • WEB: www.sfh.com